

Lightning Analysis for Mapping Faults and Identifying Exploration Sweetspots*

H. Roice Nelson, Jr.¹

Search and Discovery Article #41987 (2017)**

Posted March 13, 2017

*Adapted from oral presentation given at 2016 AAPG Pacific Section and Rocky Mountain Section Joint Meeting, Las Vegas, Nevada, October 2-5, 2016

**Datapages © 2016 Serial rights given by author. For all other rights contact author directly.

¹Dynamic Measurement LLC, Cedar City, UT, USA (roice@dynamicmeasurement.com)

Abstract

Lightning strikes occur worldwide. The National Lightning Detection Network (NLDN) database has collected 18+ years of the timing (microseconds), location (150-600 foot horizontal resolution), rise-time (microseconds), peak current (kilo-amperes), polarity (80% of strikes negative), peak-to-zero (microseconds), number of sensors recording the strike, the major and minor axis of triangulated location calculations, and chi-squared (quality measurement) for each lightning strike in the continental U. S. Historically these data were collected for insurance, meteorology, and safety markets. These data are now also used to support the oil & gas, mineral, and aquifer exploration. Lightning strike density, total wavelet time, wavelet symmetry, rate-of-rise-time, and other attributes are calculated from this database. Because the time of the lightning strike is recorded, it can be correlated with solar and lunar tides to relate lightning strikes to moon local longitude, moon phase, sun local longitude, tidal gravity, tide, and tide gradient. Lightning strikes and associated attributes also correlate with micro-seismic and earthquake timings and locations. In addition, using the simple electrical current model of lightning as a relaxation oscillator (a giant neon tube), resistivity and permittivity rock property values can be calculated for each lightning strike. Each of these attributes are calculated for lightning strike locations on the surface of the earth, then contoured or gridded, and overlaid on topographic maps. Lineaments, like fault scarps, have been mapped with 30 foot horizontal location accuracy. Subsurface values for each of these attributes are also calculated. Assuming the height of the cloud (distance the lightning travels through the atmospheric dielectric) is proportional to the Peak Current (charge buildup required to bridge the cloud to earth capacitor) and using mirror image theory (earth's surface acts like a mirror for electromagnetic pulses), values for each of these attributes can be calculated for a subsurface location at a depth beneath the strike location tied to the calculated cloud height. Lightning does not occur for clouds less than about 1,500 feet in height, nor for clouds higher than about 30,000 feet, and so the depth interval where lightning

volumes are useful is typically from 1,500-30,000 feet. Lightning strikes are passive energy pulses, and contain all frequencies. Therefore, the skin effect of the high frequency information recorded in the ~50 microsecond total wavelet time is not the controlling factor on the depth the electrical energy interacts with telluric currents. Since there are millions of lightning strikes in the 18+ year NLDN database, there are millions of subsurface (x, y, attribute) values calculated for each project area. These values can be interpolated to create volumes, and the volumes can be converted to SEG-Y files to load in standard exploration workstations. These volumes can be interpolated to have samples at the same line and trace and sample rate as any planned or existing aeromagnetic or 3-D seismic survey, and the resulting rock property or lightning attribute volumes overlaid on the seismic as if it were a velocity volume. Maps and volumes created from these lightning database attributes tie to geology and can be used to map faults and identify exploration sweetspots. Maps, volumes, and interpretations will be shown from Arizona, Louisiana, Michigan, and Texas.

Selected References

Bebout, D.G., B.R. Weise, A.R. Gregory, and M.B. Edwards, 1982, Wilcox sandstone reservoirs in the deep subsurface along the Texas Gulf Coast, their potential for production of geopressured geothermal energy: The University of Texas at Austin, Bureau of Economic Geology Report of Investigations No. 117, 125 p.

Ewing, T.E., 1986, Structural Styles of the Wilcox and Frio Growth-fault trends in Texas: Constraints on Geopressured Reservoirs: The University of Texas at Austin, Bureau of Economic Geology Report of Investigations No. 154, 86 p.

Levey, R.A., R.A. Hardage, R. Edson, and V. Pedleton, 1994, 3-D Seismic and well log data set: Fluvial Reservoir Systems, Stratton Field, South Texas: Bureau of Economic Geology, University of Texas, Austin, Texas, 78713-7509, USA.



Lightning Analysis for Mapping Faults and Identifying Exploration Sweetspots

AAPG Pacific Coast & Rocky Mountain Section Meeting in Las Vegas, NV

H. Roice Nelson, Jr.
Dynamic Measurement LLC
04 October 2016

04 October 2016

Copyright © 2016
Dynamic Measurement LLC.

Presenter's notes: This presentation summarizes the latest status of using a new geophysical data type –lightning strike data analytics –for mapping faults and identifying exploration sweetspots.

Presentation Outline

- 1. Lightning Occurs Everywhere**
- 2. Lightning Database Analytics**
- 3. Lightning Analysis & Attributes**
- 4. Rock Property & Attribute Maps & Volumes**
- 5. Arizona, Louisiana, Michigan, & Texas Examples**

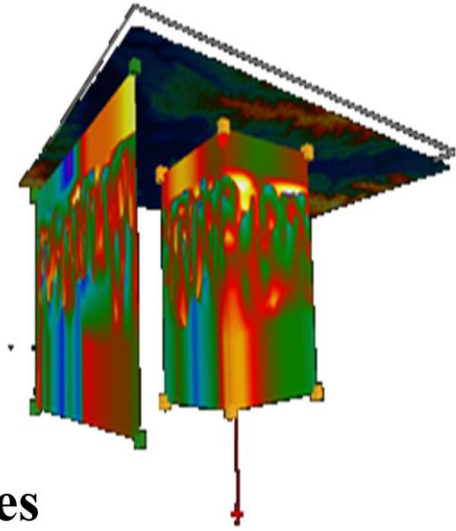

04 October 2016

1. Lightning Occurs Everywhere

5+ years of data in GLD-360 database

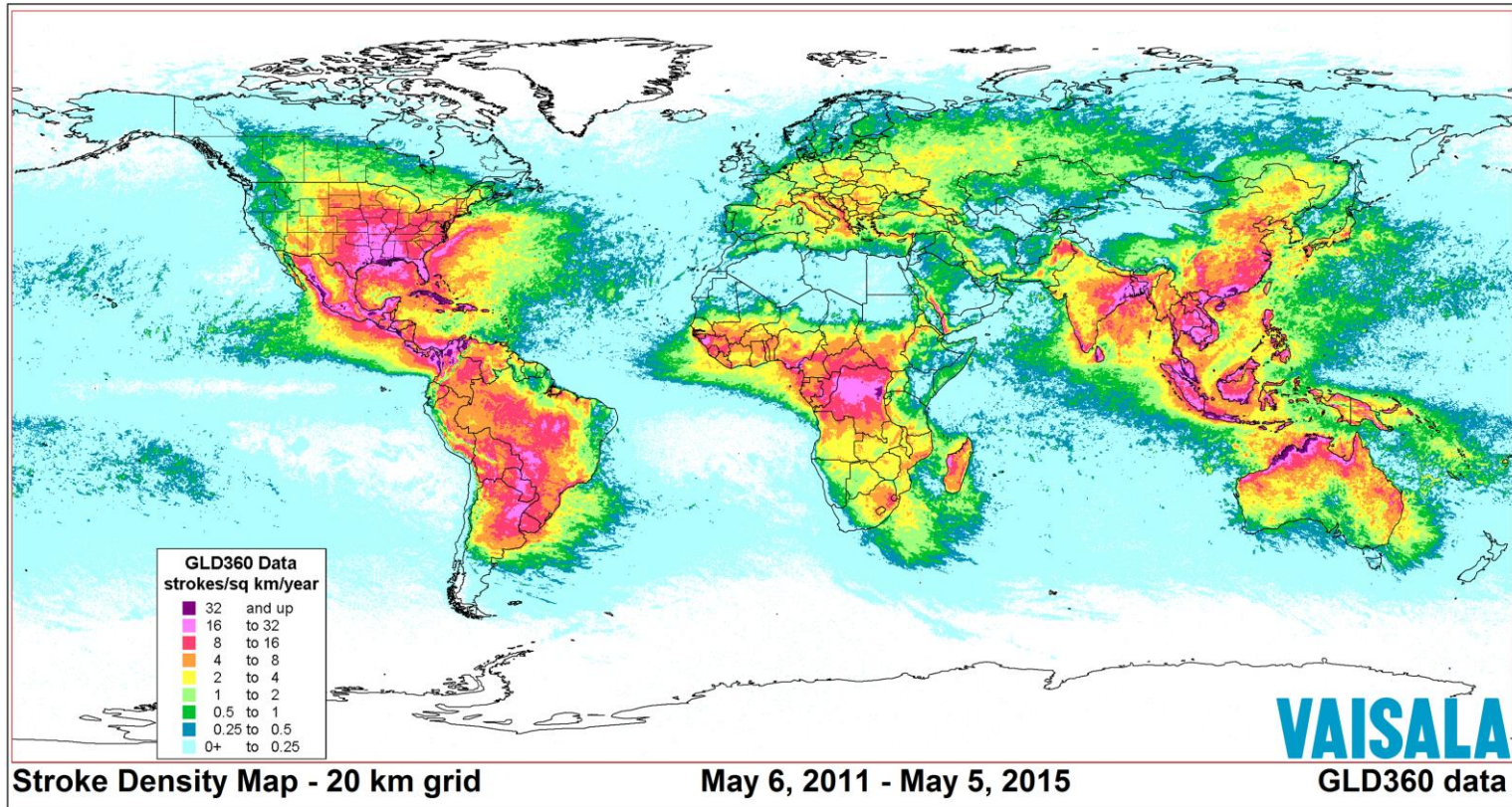

04 October 2016

Copyright © 2016
Dynamic Measurement LLC.

Presenter's notes: Lightning occurs everywhere, as shown in this worldwide map of lightning density. This data is from Vaisala's private GLD-360 (Global Lightning Database), which has been collecting data for the last 5 years. GLD-360 data is based on VLF (Very Low Frequency) sensors, and has less resolution than data collected LF (Low Frequency) sensors. It also does not include some of the attributes collected with other lightning detection networks.

The U.S. has the most complete database 18+ Years of Data in the NLDN Data Base

NLDN (National Lightning Detection Network)

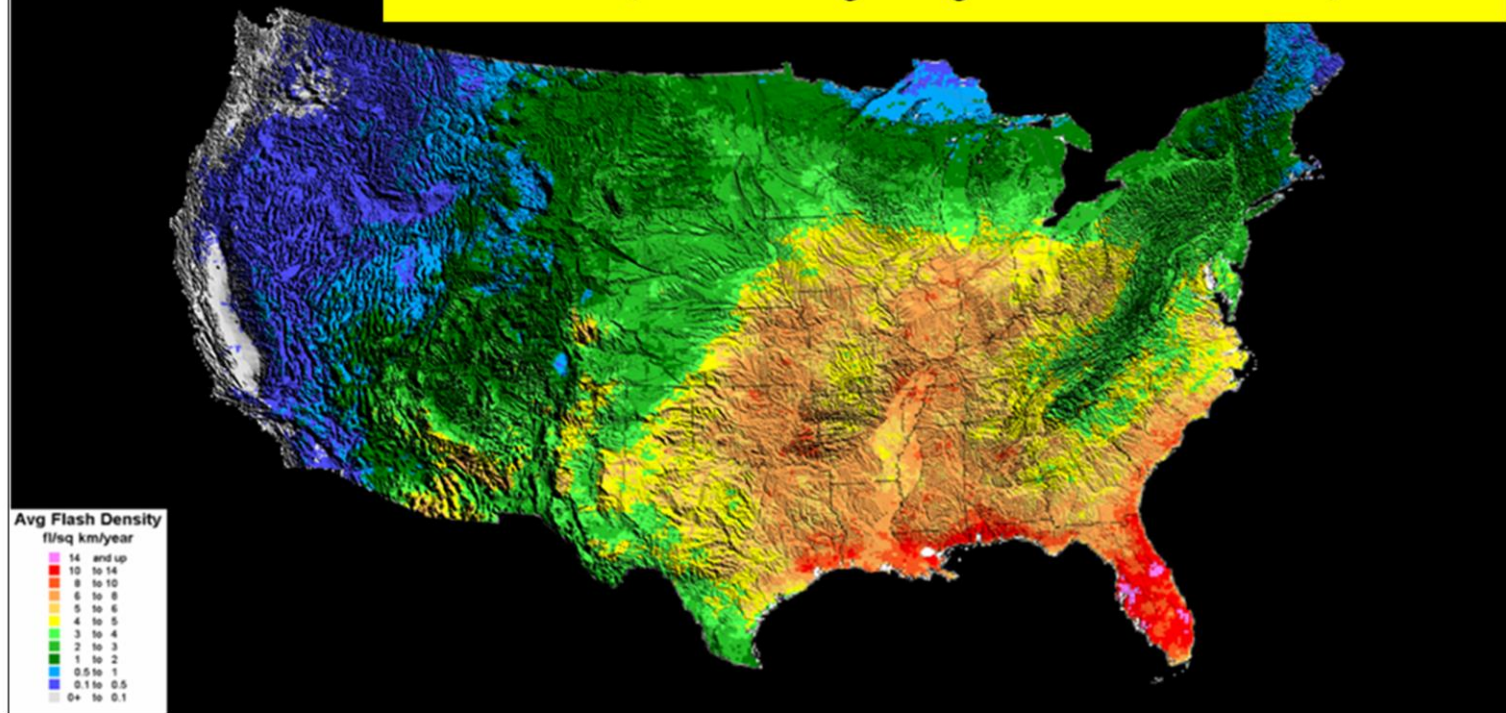

Originally Collected for Insurance, Meteorology, and Safety Reasons

04 October 2016

Copyright © 2016
Dynamic Measurement LLC.

Presenter's notes: The North American Lightning Detection Network (NALDN) is comprised of the private National Lightning Detection Network (NLDN) shown above, and the public Canadian Lightning Detection Network (CLDN) in Canada. This network of sensors was started in the early 1980's, approximately the same time we started Landmark Graphics Corporation. Dr. Richard Orville, who was a professor at the University of New York at Albany and who proved it was possible to triangulate lightning strike locations, explained how interesting this data was to insurance companies. At the time, about 60% of insurance claims on houses people said were burned down by lightning were fraudulent or misrepresented. Today the NLDN is mostly funded by insurance, meteorology weather forecasting, and airport and golf course safety industries. The map above shows the density of lightning strikes recorded by the NLDN. Note the low density of strikes across the Snake River Plains volcanic flows. This is an example showing there is a relationship between geology and lightning strike locations.

Sensors Measure Direction to Strike & Lightning Attributes

Strike Triangulated & Measurements Reconciled

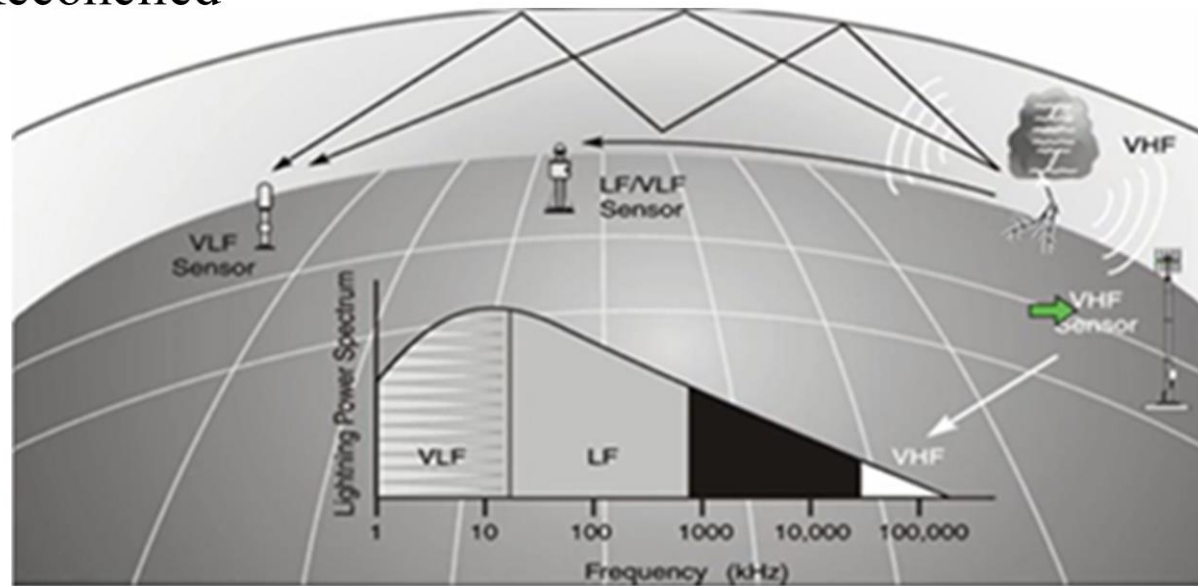

04 October 2016

Vaisala: Martin Murphy
2016 Webinar used with permission

Copyright © 2016
Dynamic Measurement LLC.

Presenter's notes: The VLF/LF sensors used to record lightning strike attributes are about 6 feet tall. When there is a lightning strike, it sends out an electromagnetic pulse. The clicks you have heard on an AM radio during a lightning storm are lightning strikes. The sensors measure magnetic inclination to give the direction. Direction coupled with time allows locations to be triangulated.

Vaisala's NLDN Lightning Detection Network

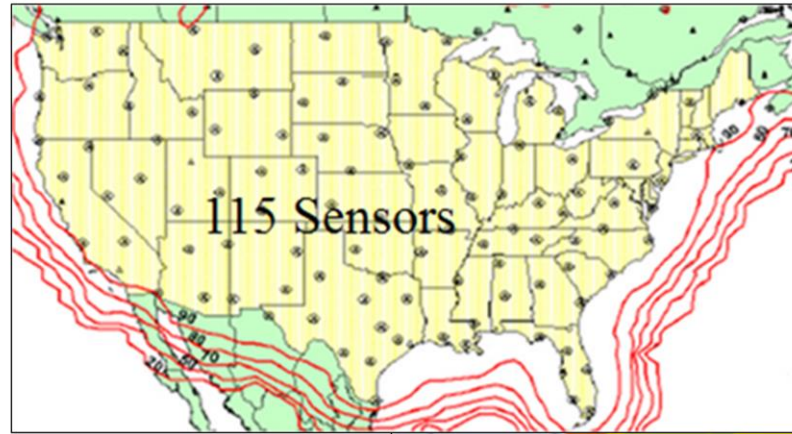

In Texas 12-24 sensors record each lightning strike

Location Accuracy:
150-600 feet

Lineament Accuracy:
10-100 feet

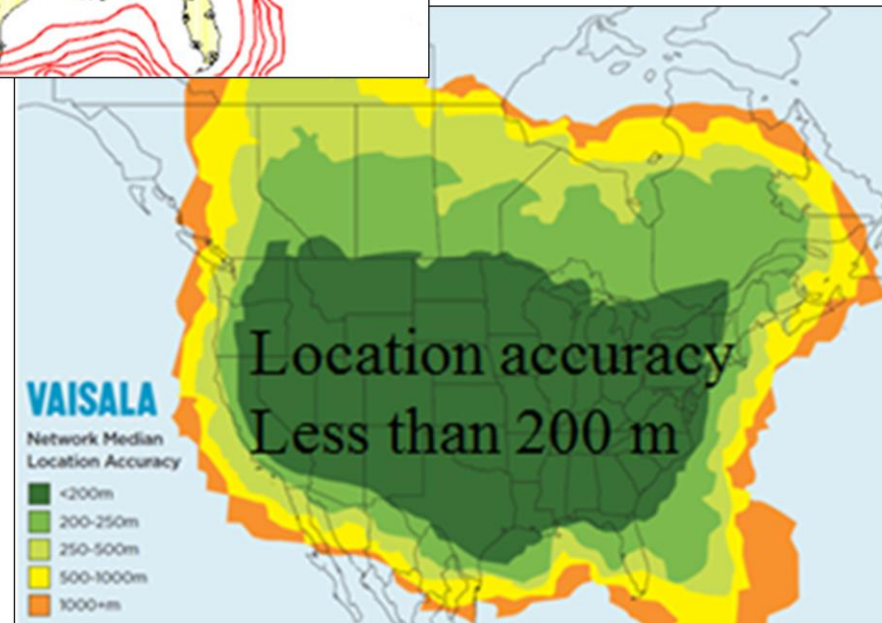

From 2016 Vaisala Webinar:
Martin Murphy,
used with permission

Copyright © 2016
Dynamic Measurement LLC.

04 October 2016

Presenter's notes: There are 115 lightning detection sensors in the NLDN, providing coverage across the continental United States. These sensors have a flash detection efficiency of over 95%. Horizontal accuracy is published as being less than 200 meters, and Dynamic Measurement has demonstrated this accuracy can be 50 meters or even 5 meters in some cases. This means the horizontal accuracy of lightning strike locations is similar to the trace location accuracy for a 3-D seismic survey. A typical lightning strike in Texas is recorded on 14 to 24 sensors, where some of the sensors are more than 300 miles away.

2. Lightning Database Analytics

- Typical projects have millions of lightning strikes.
- To date all projects have tied subsurface control.
- Attributes are measured or calculated for lightning strike locations, then contoured or gridded.
- Lightning strike density and attribute values cluster, and these clusters are somewhat consistent over time.
- Lineaments, like fault scarps, have been mapped with 30 foot horizontal location accuracy.



04 October 2016

Copyright © 2016
Dynamic Measurement LLC.

Presenter's notes: A 214-square-mile lightning analysis projects in the Gulf Coast, where there are on average 26 lightning strikes per square mile per year, has 1,000,000 lightning strikes in the 18-year NLDN evergreen database. A project of the same size in the deserts of California will have 150,000 lightning strikes in the NLDN database. The results from data mining these amounts of data are remarkably good. Each project Dynamic Measurement has done to date ties available subsurface control. This is because, even though each lightning strike is different because of meteorological factors, the geology is consistent over time. Yet, near surface soils change with water saturation. However, it is the geology beneath the weathering layer, which is where the telluric currents are, which affects lightning strike locations. Remember, lightning is coming from 5,000 to 25,000 feet in the atmosphere, and water saturation from a rainstorm only impacts the first few feet of the weathering layer. The fact that lightning strike density and lightning strike attribute values cluster, and these clusters are somewhat consistent over time shows geologic control. Also lineaments, like fault scarps and stratigraphic pinchouts, have been mapped with 30 foot horizontal accuracy.

Lightning Measurements

- Location
- Time and Duration
- Rise Time
- Peak Current
- Polarity
- Peak-to-Zero
- Density
- Major/Minor Axes
- Chi-Squared

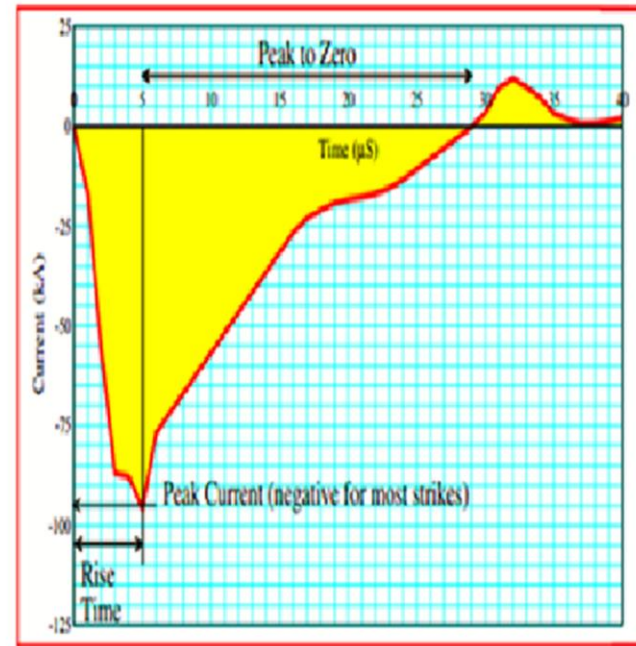
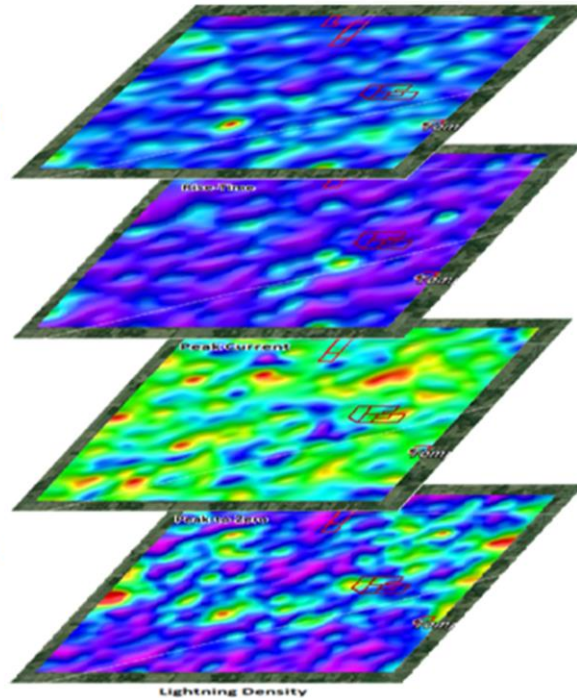

- Other attributes calculated from these measurements.
- The time of the lightning strike is correlated with solar and lunar tides.
- Measurements separated by time.

04 October 2016

Copyright © 2016
Dynamic Measurement LLC.

Presenter's notes: A pulse of energy travels out from each lightning strike. Data related to these pulses are collected by NLDN sensors and automatically combined to give a single set of recordings for each lightning strike. The sensors measure the beginning of an event to the nearest microsecond (10^{-6} seconds). The sensors have a magnetic inclination, which gives the direction of the pulse. Triangulating these measurements, somewhat similar to the way earthquake locations are triangulated from multiple sensors, provides a location. Rise-Time starts once the electrical energy exceeds the background electrical noise on multiple sensors for a specific time. Rise-Time ends with Peak Current. This Peak Current has polarity and can be positive or negative. Most lightning strikes are negative, and come from the base of clouds forming a thunderstorm. Positive strikes tend to come at the end of a storm and to come from the top of the clouds. Peak-to-Zero is the time from Peak Current to when the energy returns to the background electrical noise. These values are gridded, averaged within cells, and mapped to create the top three maps above (Rise-Time, Peak Current, and Peak-to-Zero). These maps were generated for a project in Michigan. The bottom map above is generated by counting the number of strikes, which occur in a specific sized grid cell, and summing this number to create a map of lightning strike density.

3. Lightning Analysis & Attributes

1. Analysis area selected.
2. Patented and Patent-Pending Processes produce maps and volumes of derived rock properties and lightning attributes.
3. Existing geology and geophysics integrated with new data.

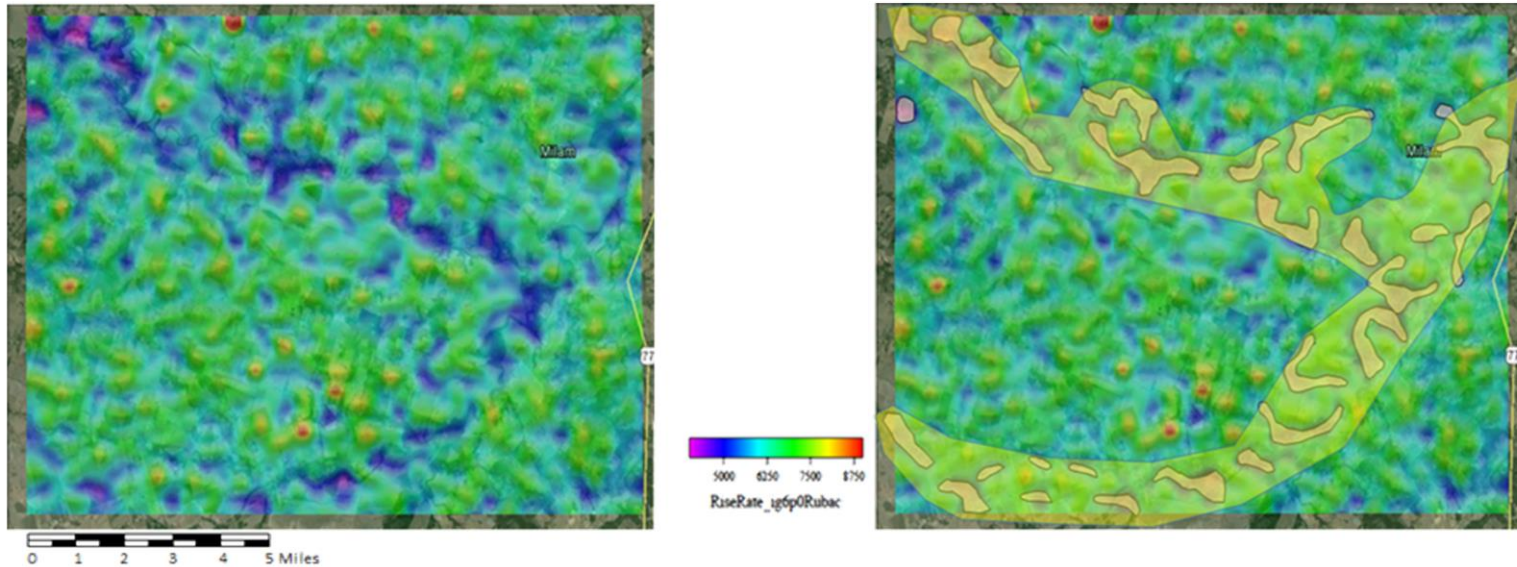

Lightning Attribute: Rate of Rise-Time – Milam County, Texas

04 October 2016

Copyright © 2016
Dynamic Measurement LLC.

Presenter's notes: The Lightning Analysis Process starts with selecting an area to evaluate. Lightning data is ordered over this area. Once the data are received, a series of patented, patent pending, and trade secret processes are run on this data to clean the data and produce rock property and lightning attribute maps and volumes. The left map above shows the rate-of-rise-time (first derivative of the Rise-Time) over a project area in Milam County, TX. An interpretation of this area shows probable near-surface point bars close to the surface where the confluence of two rivers in Milam County occurs. Once the maps (xyz, pdf, and kmz files) and volumes (SEG-Y or voxel ASCII files) are generated, the lightning-derived data are loaded into a standard geophysical workstation.

4. Rock Property & Attribute Maps & Volumes

Key Assumptions:

1. Lightning occurs when there is sufficient charge to bridge the capacitor.
2. Lightning is affected by geology to a depth proportional to cloud height, as derived from Peak Current

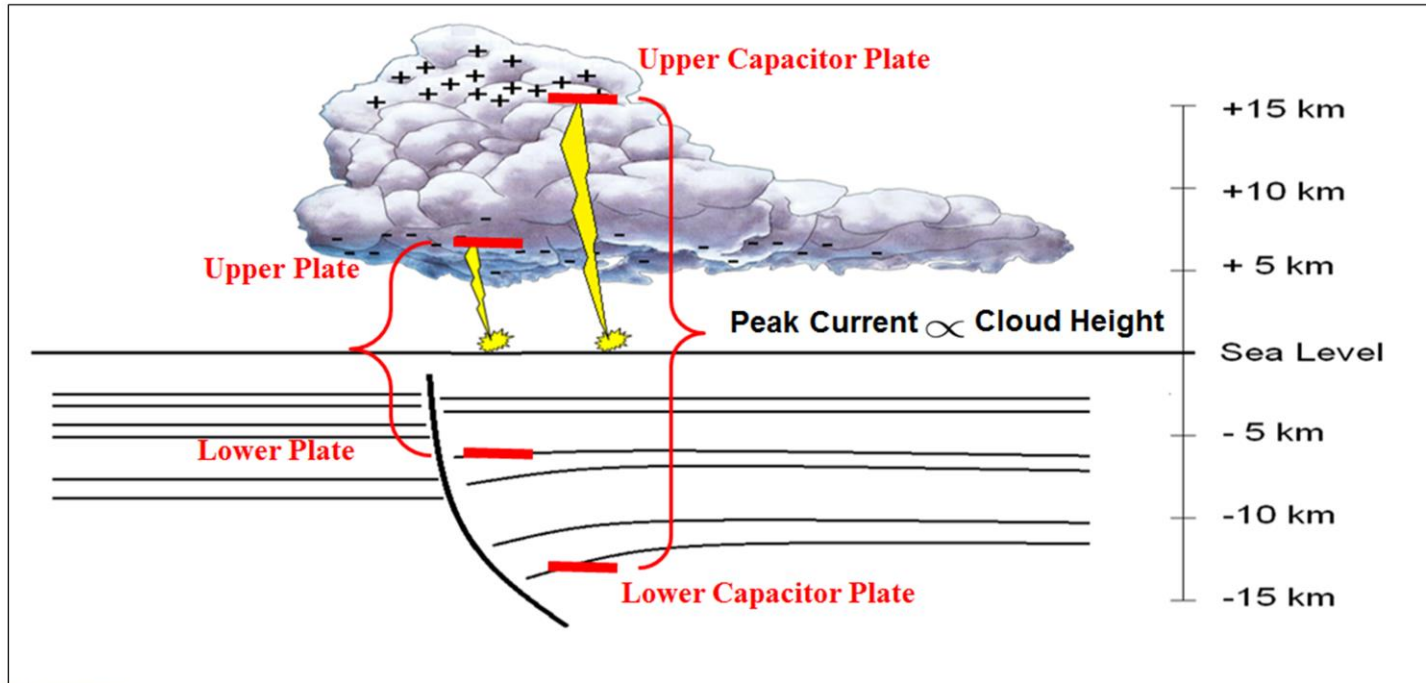

04 October 2016

Copyright © 2016
Dynamic Measurement LLC.

Presenter's notes: Many assumptions are made when developing a new geophysical data type. We assume the strike locations are correct. We have demonstrated this visually and with calculations tied to radio towers and surface cutting faults. We assume there is a relationship between the geology and the recorded lightning attributes. This is demonstrated with map results. To calculate a depth component influencing recorded data, we first assume the Peak Current is proportional to the height of the cloud, which height is the capacitor distance the strike must bridge. The atmosphere is a very good insulator, with an electrical conductivity of $0.03-0.08 \times 10^{-14}$ Siemens per Meter. Assuming a typical sedimentary rock has 5% porosity, the electrical conductivity of rocks is 5.0×10^{-4} Siemens per Meter, or about 10^{10} times the conductivity of air. It takes more Peak Current to bridge a larger capacitor distance. Our second assumption is that the depth telluric currents are influencing electrical currents in the atmosphere is mirrored around the surface of the earth.

Relaxation Oscillator Physics and Lightning (a giant neon tube)

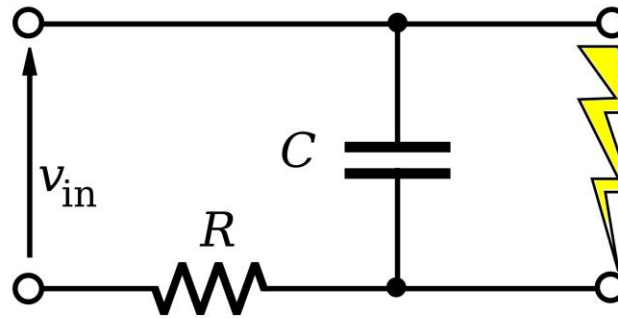
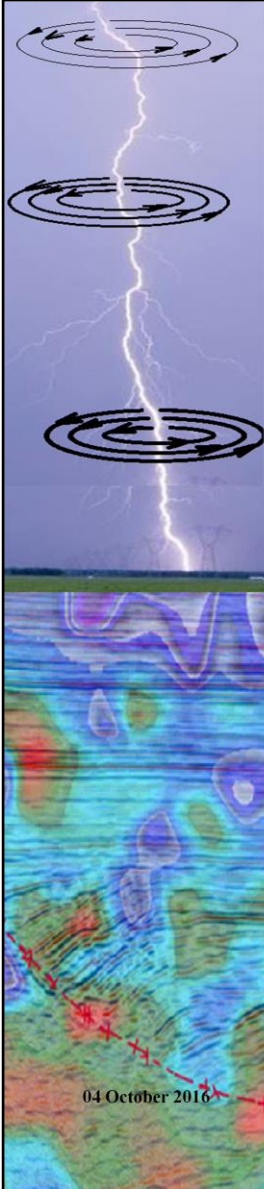

- The atmospheric capacitor is like a relaxation oscillator
- Just an additional resistance (R_2) limiting the current

- R_2 is the resistance between the lightning strike point and the bottom plate of the capacitor

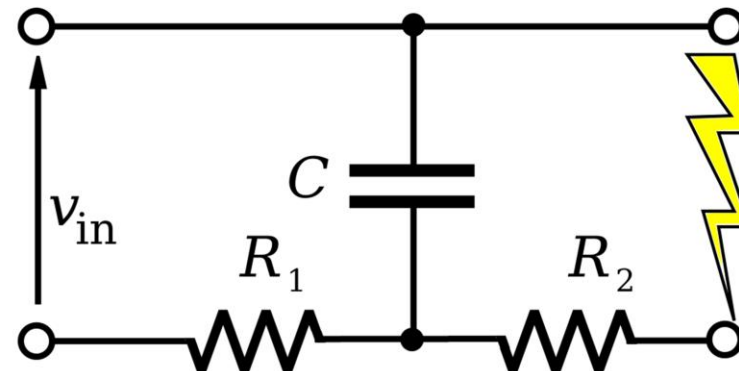

Copyright © 2016
Dynamic Measurement LLC.

Presenter's notes: One way to look at this is that a lightning strike is like current flowing along a wire. There is a magnetic field generated orthogonal to the flow of current. These currents are gigantic, about 5 to 50 thousand amperes. The magnetic fields are what charge and interact with telluric currents in the subsurface, all the way to the Mohorovičić discontinuity. In terms of physics, lightning strikes can be compared to a relaxation oscillator, or a giant neon tube. With a neon light, current is built up from an input voltage until it flows through a resistor and builds up sufficient charge to bridge a capacitor. With lightning, there is an additional resistance, the resistance in the earth between the strike plate and the bottom plate of the capacitor, which is R_2 in the diagram. R_2 is calculated as the apparent resistivity in the lightning relaxation oscillator circuit. We can place this calculated value at the surface, and average the values with a specified cell size to create a rock property map of apparent resistivity at the surface. Alternatively, we can place this calculated value in the subsurface at a depth proportional to the cloud height (Peak Current), and then placing thousands or millions of points in the subsurface, interpolate between them to create an apparent-resistivity rock property volume.

Lightning and the Induced Polarization Effect

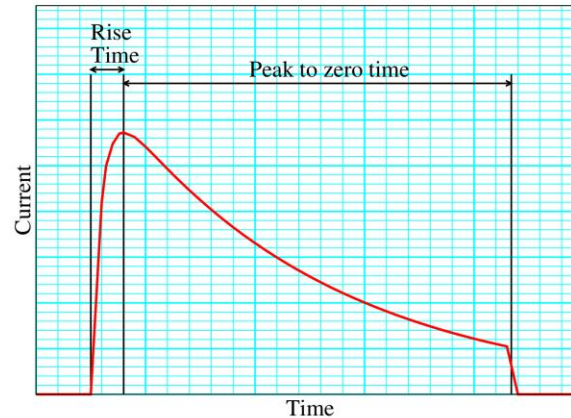

- By treating this steep onset as charging a capacitor (C_2) through a resistor (R_3), an apparent capacitance can be calculated.
- From the apparent capacitance a value for apparent permittivity can be calculated

- Lightning does not have a square waveform
- But it does have a very steep onset
- Variations in the onset as measured (rise-time) show the IP Effect

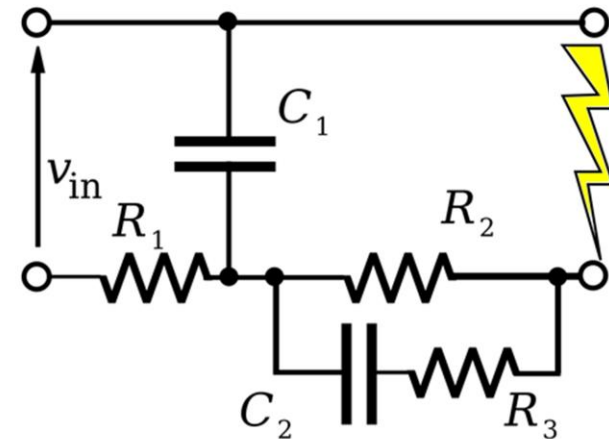

Copyright © 2016
Dynamic Measurement LLC.

Presenter's notes: These concepts can be extended to calculate another rock property, apparent permittivity. The IP, or Induced Polarization effect, is an exploration method measuring the slow decay of voltage in the ground following the cessation of an excitation current pulse. This decay is due to the permittivity, or the capacitance of 3-dimensional materials. Typically, the excitation current pulse is a square waveform. Lightning does not have a square waveform, but it does have a very steep onset. Variations in this steep onset are measured as Rise-Time, and show the IP effect. By treating this steep onset as the charging of a capacitor (C_2) through a resistor (R_3), an apparent capacitance can be calculated. From the apparent capacitance, a value for apparent permittivity can be calculated. These values can be averaged within grids at the surface to create maps of apparent permittivity, or placed in a position relative to their position in the subsurface, and interpolated to create an apparent permittivity rock property volume.

04 October 2016

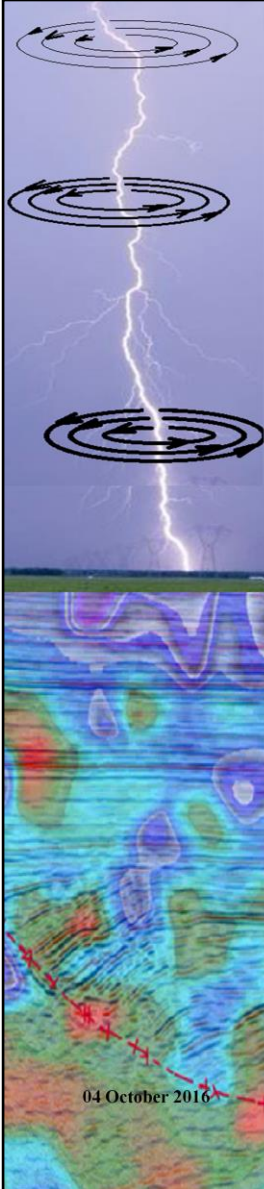

Skin Depth is NOT the Controlling Factor

Charging Telluric Currents:

Lightning strikes are passive energy pulses, and contain all frequencies.

The skin effect of the high frequency information recorded in the ~50 microsecond total-wavelet time does not control the depth electrical energy interacts with telluric currents.

Interval of Interest:

Traditional lightning does not occur in clouds less than ~1,500 feet in height, nor for clouds higher than ~30,000 feet.

The depth interval where lightning volumes are useful is typically from 1,500-30,000 feet.

Data Distribution:

Volumes converted to SEG-Y files for workstations.

Volumes interpolated to match aeromagnetic or 3-D seismic surveys.

Resulting rock property or lightning attribute volumes are overlaid on the seismic or other geologic cross-sections like a velocity volume.

Copyright © 2016
Dynamic Measurement LLC.

Presenter's notes: Just as a 30-50 foot tall oak tree does not control where a 5,000-to30,000-foot lightning strike occurs, the skin depth of a lightning strike, which is at most a few tens of feet, does not control either where lightning strikes or the measured attributes of a lightning strike. Lightning strikes are passive energy pulses, and contain all frequencies. While the effect of the lightning strikes at the surface is limited to the skin depth, the 5-50 kiloamps per strike interacts with geology miles into the subsurface. For lightning strikes, the dominant frequency is about 10 hertz, based on typical resistivity of earth materials of 100 to 10,000 ohm-meters, and relative permeability of 1 (except where there is significant magnetite present). This places the skin depth in the range of 150 to 1,500 feet. At depths of 600 to 6,000 feet, the current density is still about 2% of the near-surface value. A 20,000-ampere lightning strike will have an initial current density of two million amperes per meter square, and 2% of this is still 40,000 amperes per square meter. It is therefore not surprising that currents from a single lightning strike are a major contributor to telluric currents, which currents have been measured by magnetotelluric exploration since the 1950's. Results suggest the useful depth interval of lightning-derived rock property and lightning attribute volumes is between 1,500 and 30,000 feet, with most projects having useful data between 4,000 and 15,000 feet. These volumes are interpolated to match aeromagnetic, 3-D seismic or other grids, and converted to SEG-Y or voxel ASCII files for easy loading on geophysical workstations.

Stratton Seismic Sections, South Texas

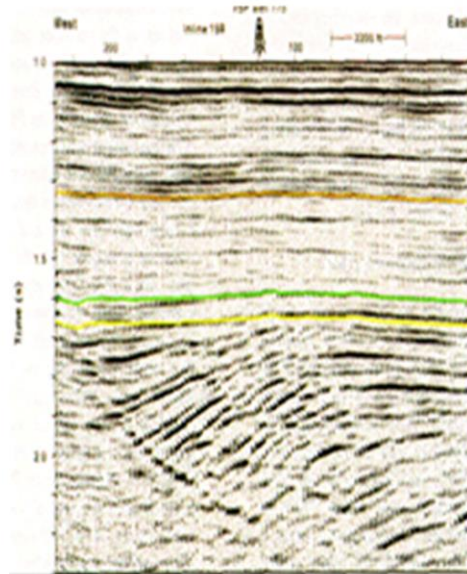

Frio Horizons
Fluvial – Deltaic
Sands



Published BEG Stratton
Data to 2.3 seconds
(Hardage, 1986)

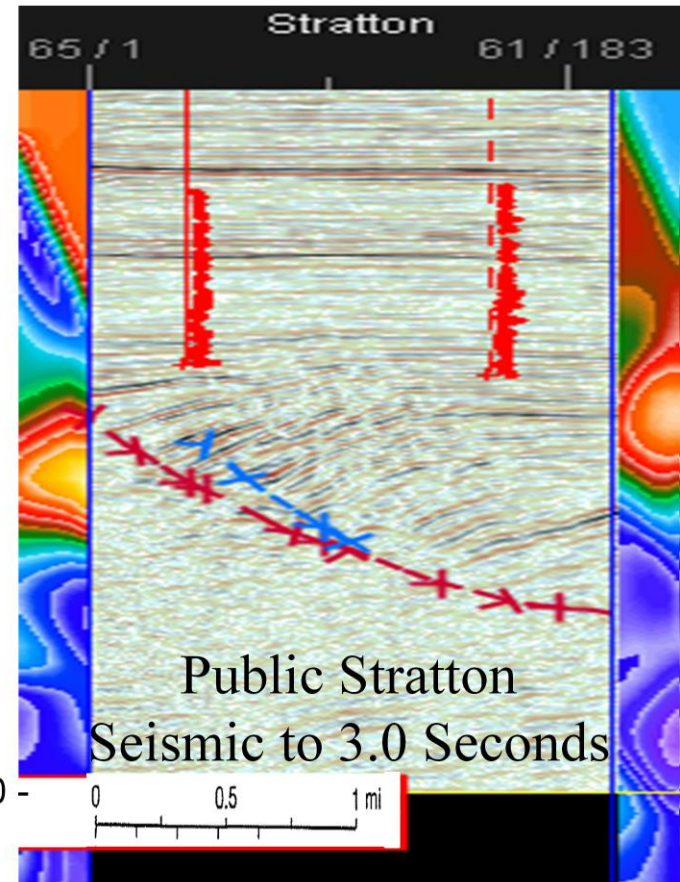

Public Stratton
Seismic to 3.0 Seconds

04 October 2016

Copyright © 2016
Dynamic Measurement LLC.

Presenter's notes: The next set of slides show lightning-derived rock property and lightning attribute volumes created in South Texas over the area surrounding the Stratton 3-D seismic survey, which was made public by the Bureau of Economic Geology (BEG) at The University of Texas in Austin. Published Stratton sections, shown on the left, go down to 2.3 seconds, and show a nice Vicksburg expansion fault. The released seismic data, shown on the right, goes down to 3.0 seconds. There is a significant difference in the vertical frequency of lightning-derived rock property and lightning attribute volumes and seismic or well logs, as shown by the apparent-resistivity volume behind the seismic behind the well logs shown on the right.

Study Area around Corpus Christi

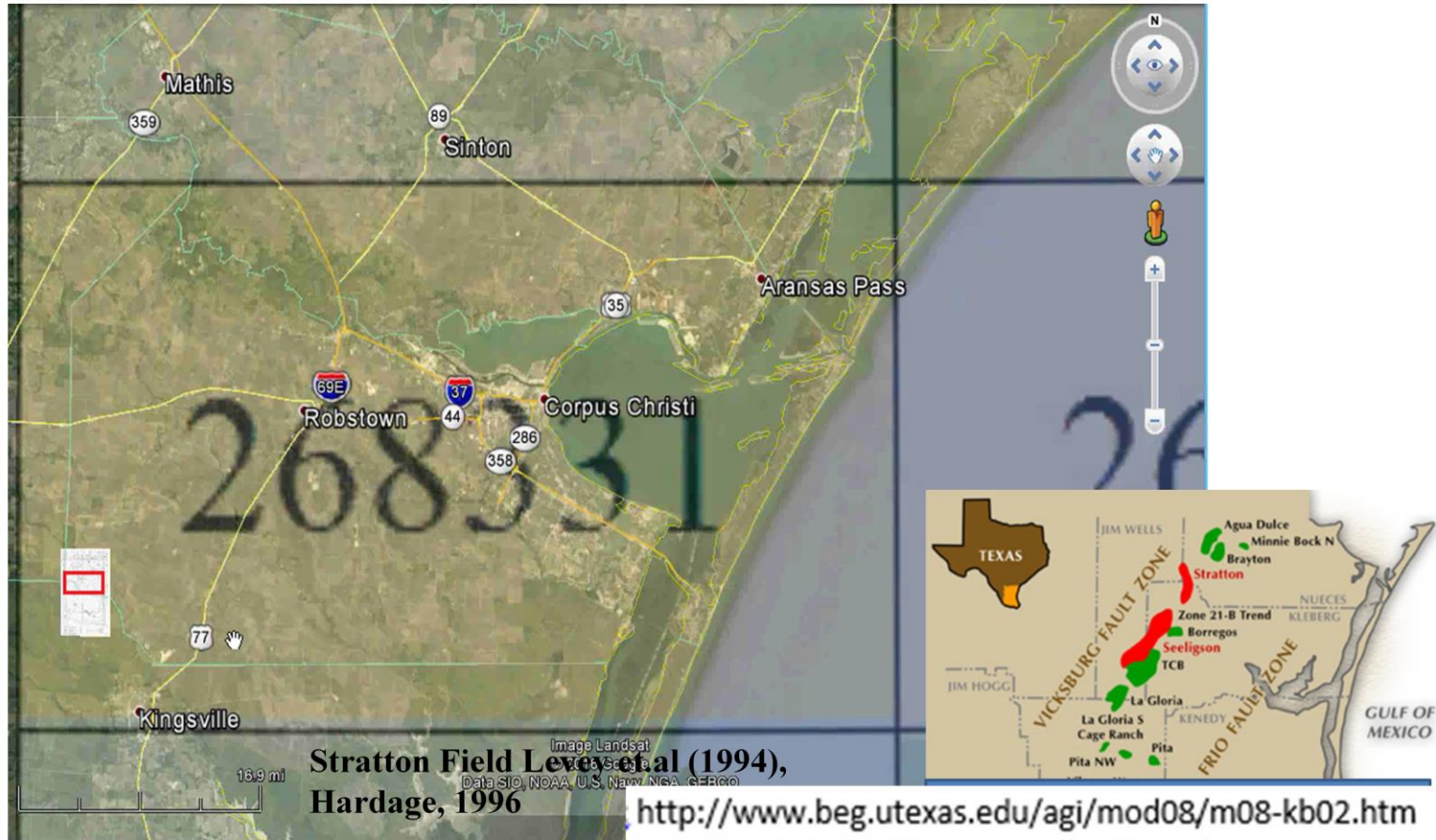

04 October 2016

Copyright © 2016
Dynamic Measurement LLC.

Presenter's notes: The Stratton seismic survey is located west of Corpus Christi Bay, as shown here. The approximately 70 x 20 mile area, labeled 268331, is the area a set of lightning-derived rock property and lightning attribute volumes were generated for this talk. This area includes both the BEG's Stratton seismic survey, and three geologic cross-sections published by Tom Ewing at the BEG.

Stratton Apparent-Resistivity Sections

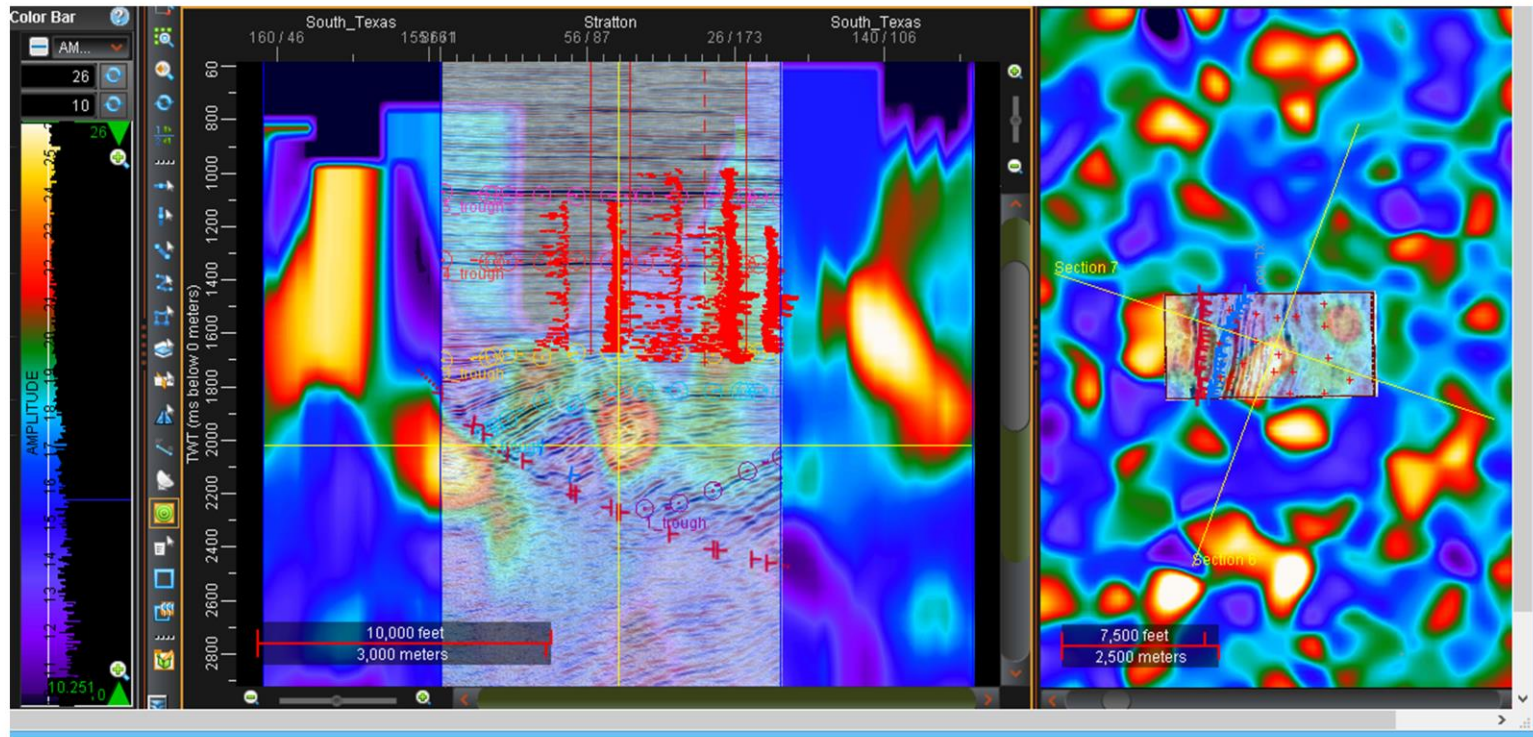

Working on calibrating depth and calculated vs. measured resistivity

04 October 2016

Copyright © 2016
Dynamic Measurement LLC.

Presenter's notes: Here we show the lightning-derived apparent-resistivity volume overlaid on the seismic displays as both a dip cross-section on the left and a horizontal section on the right. The dip cross-section goes from the west-northwest to the east-southeast diagonally through the Stratton time-slice section. The time-slice section is a little deeper than 2000 milliseconds, as shown by the horizontal line on the vertical cross-section. High apparent resistivities are the brighter yellow and red colors, and high conductivities are the blues and purples. We are still working on accurately calibrating both (1) the depth of lightning-derived rock properties and lightning attributes, and (2) the calculated and measured values of apparent resistivity.

Study Area - Geology and Structure Corpus Christi from Ewing (1986)

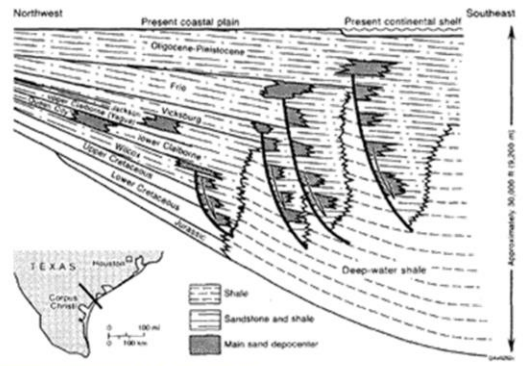
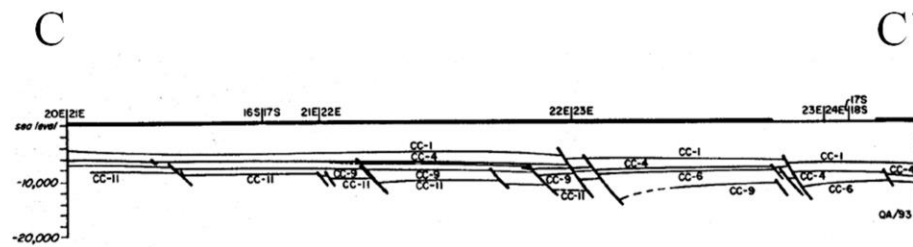
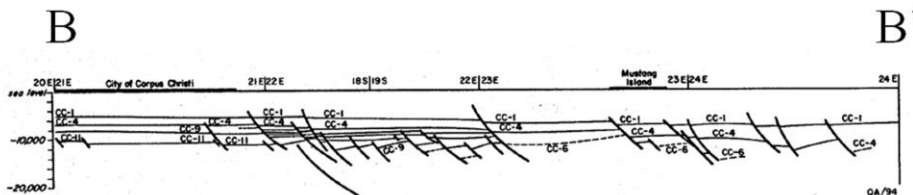
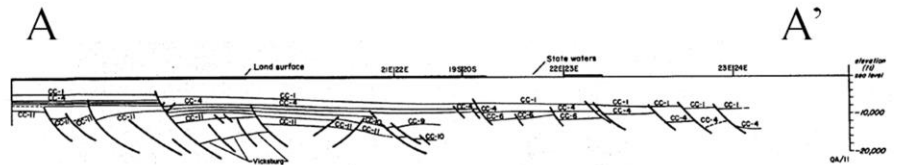

From Levey, et al, 1994
Bebout and others, 1982

Copyright © 2016
Dynamic Measurement LLC.

Presenter's notes: In 1986, Tom Ewing at the BEG published a regional geological study of the Corpus Christi Area. One of the key issues with introducing a new geophysical data type is demonstrating how this data relates to geology. Dynamic Measurement has done over 20 projects, and so far every project has results which tie back to local geology and the control available for the specific area. Dynamic has over 21,000 square miles of South Texas lightning data, which we use for testing and product development. This article by Tom Ewing describes faults in the 21,000 square mile area we recently reprocessed. The above map shows the location of three cross-sections, A-A', B-B', and C-C', through the eastern portion of this area around Corpus Christi, Texas. The cross-section schematic on the lower left shows expansion at the Wilcox, Vicksburg, Frio, and Oligocene-Pleistocene.

2016 Lightning-Derived Resistivity Cross-Sections Match Geology on 1986 Ewing Interpretation Overlay

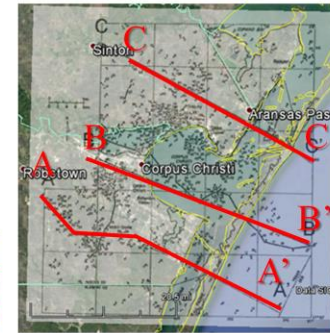
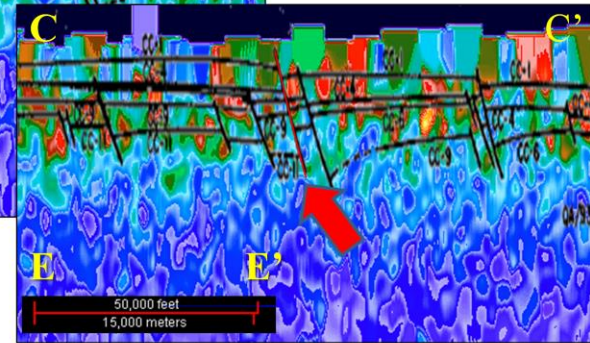
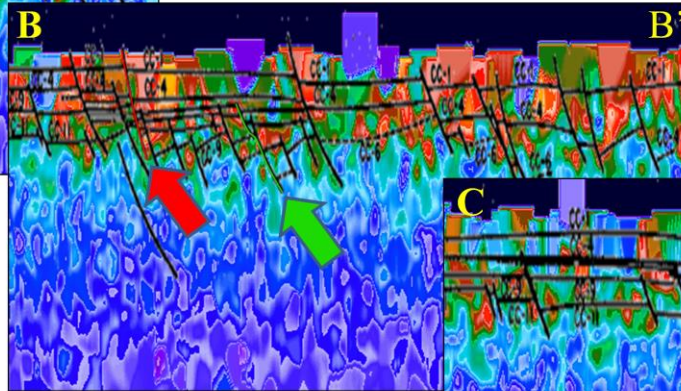
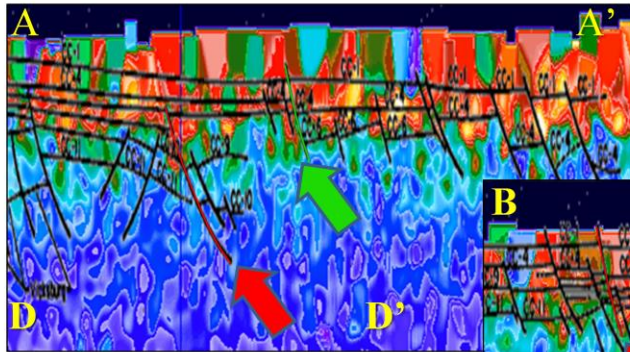

Red and Green Arrows show faults correlated between Ewing cross-sections using Ewing fault plane maps

(Fault Overlays Ewing 1986)



Copyright © 2016
Dynamic Measurement LLC.

Presenter's notes: This slide overlays the 1986 geologic cross-sections (A-A', B-B', and C-C') on equivalent apparent-resistivity cross-sections calculated from lightning strike data collected between 1998 and 2011. These are two completely independent data sets. Two faults were correlated from cross-section to cross-section, the red fault and the green fault, based on faults on horizon maps in Tom Ewing's paper. It is exciting to see how well the Ewing-defined faults define exactly where there are vertical offsets along the apparent-resistivity sections. It is also very interesting that there are high resistivity "plumes" above several of these faults in the horizontally layered beds above some of the buried faults. The first thing that comes to mind is that these high resistivity "plumes" are defining hydrocarbon migration pathways. Also, note the extent of D-D' on section A-A' and the extent of E-E' on section C-C'. The next three slides will zoom in on these two areas.

D-D' Close-Up on Graben on A-A' without overlay

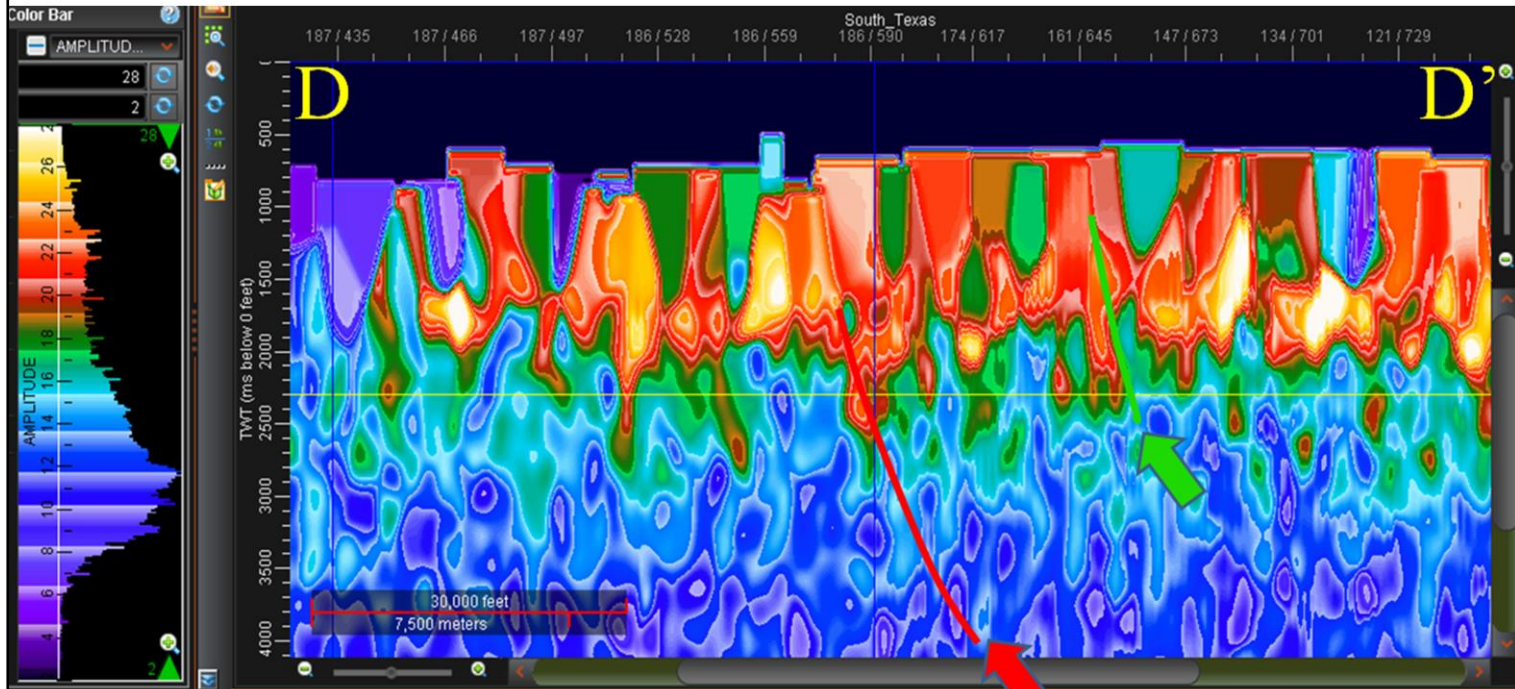

Red and Green Faults were major faults on Ewing's maps. Note high apparent-resistivity events (bright) appear to have plumes above these faults.

04 October 2016

Copyright © 2016
Dynamic Measurement LLC.

Presenter's notes: Here is a zoom in on A-A' to D-D', just showing the apparent-resistivity cross-section and the location of the red fault and the green fault. The color bar is graduated to show subtle changes in the calculated apparent resistivity. Recall that this section is generated by calculating apparent resistivity for each lightning strike, placing these calculated values proportional to the height of the cloud (Peak Current), and then interpolating in three dimensions to create a 3-D apparent-resistivity volume. There are fewer control points that are shallow, because there are fewer lightning strikes from low clouds. Thus, the interpolation makes the results have a lower spatial frequency appearance. The same thing happens at depth. The sweet zone appears to be between 4,000 and 20,000 foot depths.

D-D' Close-Up on Graben to the west

Interpretation 1986 by Tom Ewing, Apparent Resistivity 2016 from Lightning Databases

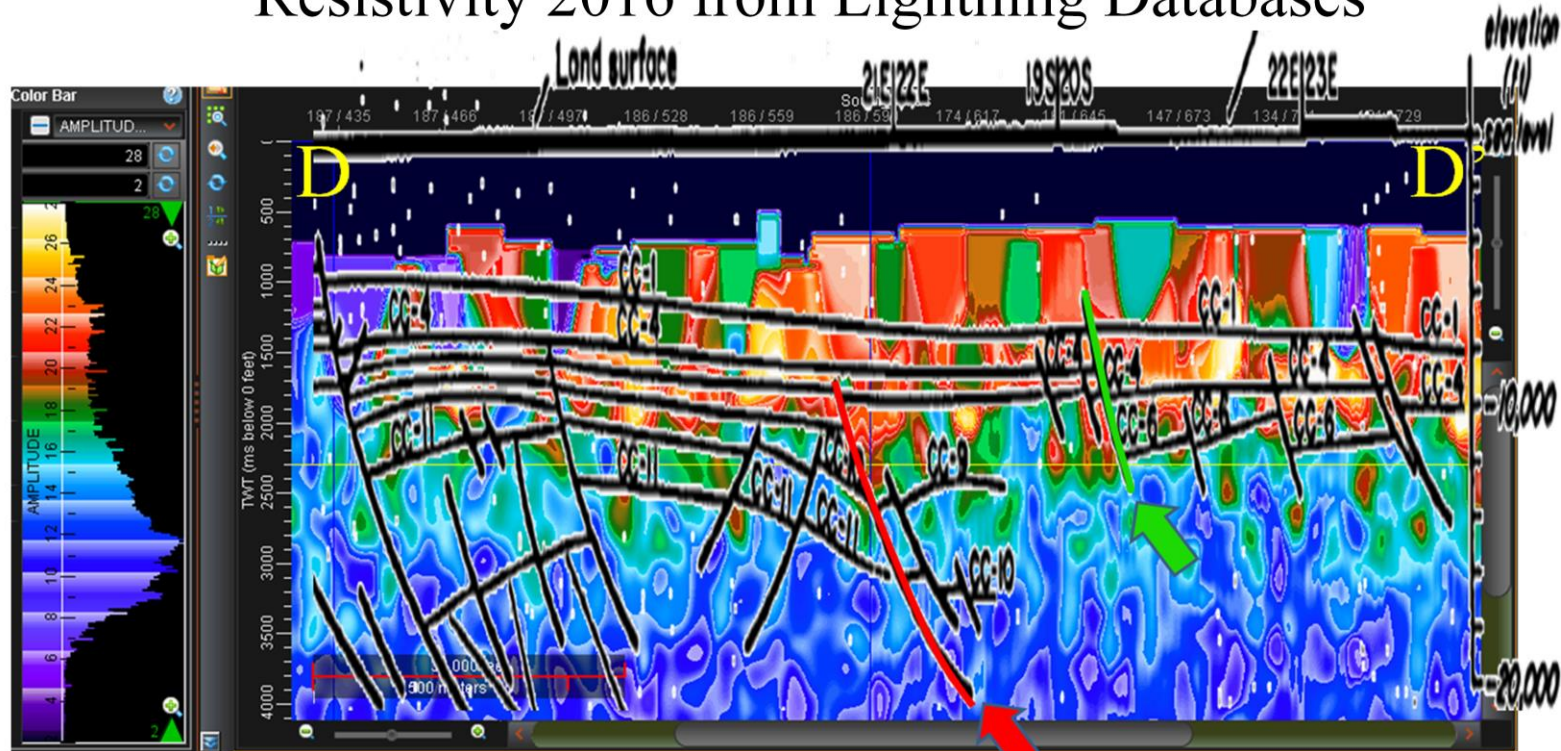

Note: interpretation by Tom Ewing in 1986. The resistivity section calculated from lightning in 2016. Co-located sections show breaks where faults were interpreted. There are resistivity plumes tied to faults.

04 October 2016

Copyright © 2016
Dynamic Measurement LLC.

Presenter's notes: Here Tom Ewing's 1986 fault interpretation is overlain on the apparent-resistivity cross-section. Again, note how well the Ewing-defined faults define exactly where there are vertical offsets along the apparent resistivity, and the relationship of the high-resistivity "plumes" above several of the buried faults. From a frontier and regional exploration standpoint, it is exciting to realize this new geophysical data type has the potential to help us map hydrocarbon migration pathways.

E-E' on the Northwest End of Ewing's C-C'

Note offsets in adjacent "Packages" of Higher Values of Apparent Resistivity

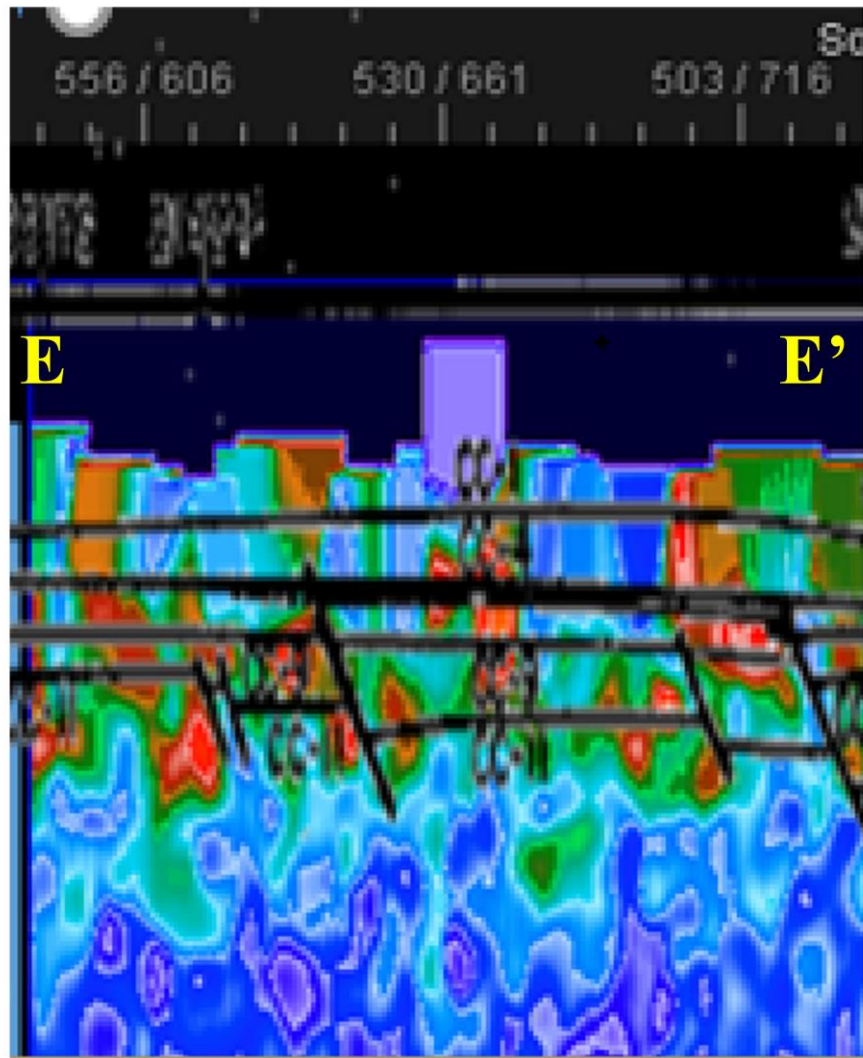

04 October 2016

Copyright © 2016
Dynamic Measurement LLC.

Presenter's notes: This section is the E-E' portion of 1986 Ewing's C-C' cross-section overlain on an apparent-resistivity section. There was no manipulation of the two different data sources. The apparent-resistivity section was generated as close as possible to Tom Ewing's C-C' section, and then his interpreted results were overlaid. There is an excellent correlation between Ewing's faults and the breaks in the calculated apparent-resistivity cross-section.

Apparent-Resistivity Extension of Ewing (1986) A-A' through Stratton seismic data

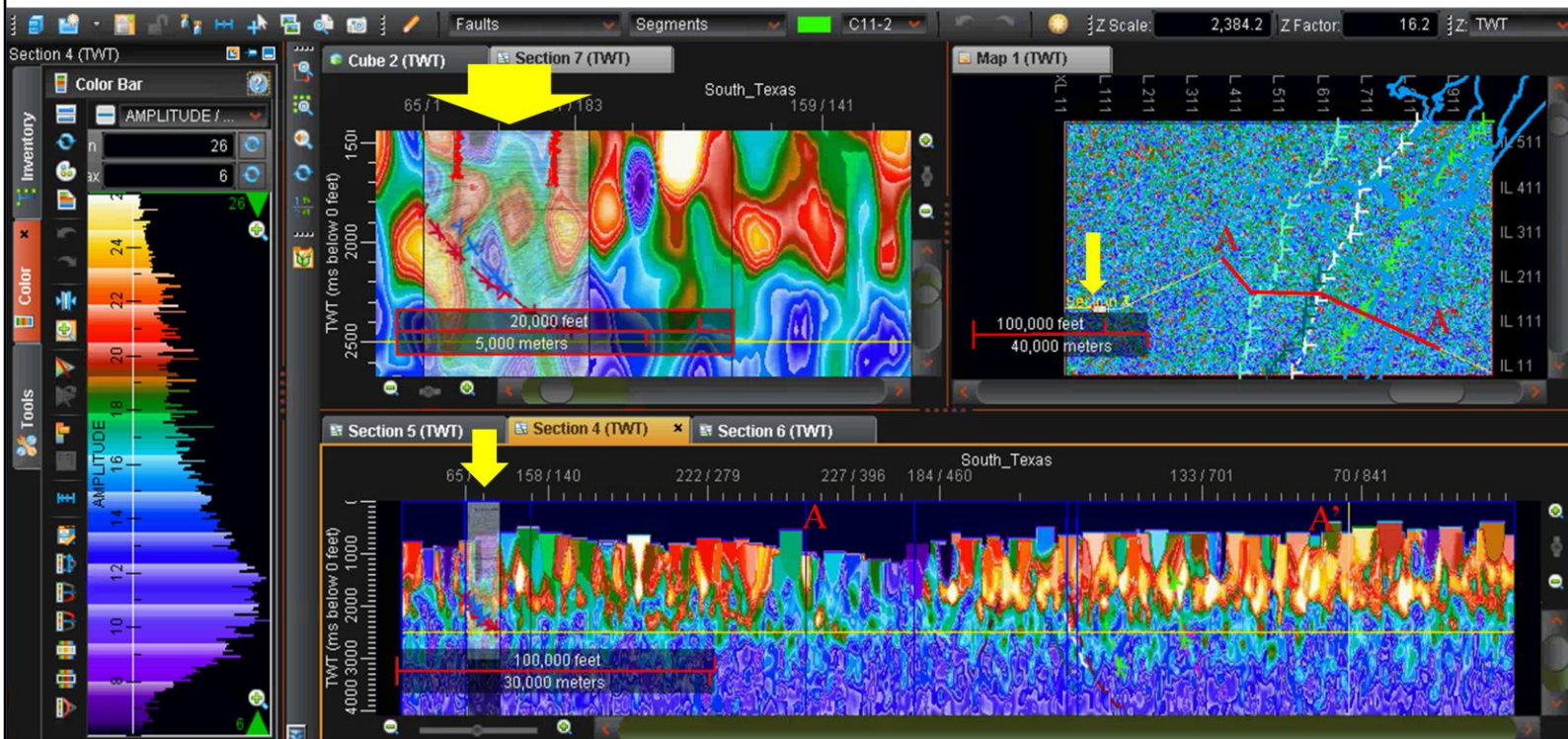

(ohm-meters)

04 October 2016

04 October 2016

Copyright © 2016
Dynamic Measurement LLC.
Copyright © 2016
Dynamic Measurement LLC.

2016 AAPG P + R M 22

Presenter's notes: Because of the time available in this type of professional presentation, the next series of slides will be stepped through very quickly. Each slide shows the same sections as is shown here. The time-slice section on the upper right covers the 268331 area defined in slide 15 above. There are three faults, which were picked on the apparent-resistivity cross-sections, to show the fault trend orthogonal to cross-section A-A'. The time-slice is at 2500 milliseconds. The time-slice also shows the location of the extension of the A-A' apparent-resistivity cross-section, in the bottom panel, which starts at the west side of the area, goes east through the Stratton survey, northeast to A, along A-A' to A', and then southeast to the corner of the area. The upper right cross-section is a zoom across the western portion of the bottom section. The black vertical line at the eastern edge of the horizontal scale in the bottom of the upper-right cross-section display shows where this line bends to the northeast. Location of the Stratton seismic data is highlighted with a yellow arrow on each section. The attribute shown in all three windows of this display is apparent resistivity. The next 18 slides will show 18 lighting derived attributes along vertical and horizontal cross-sections at these same locations.

1 of 18 Lightning Attributes - Density

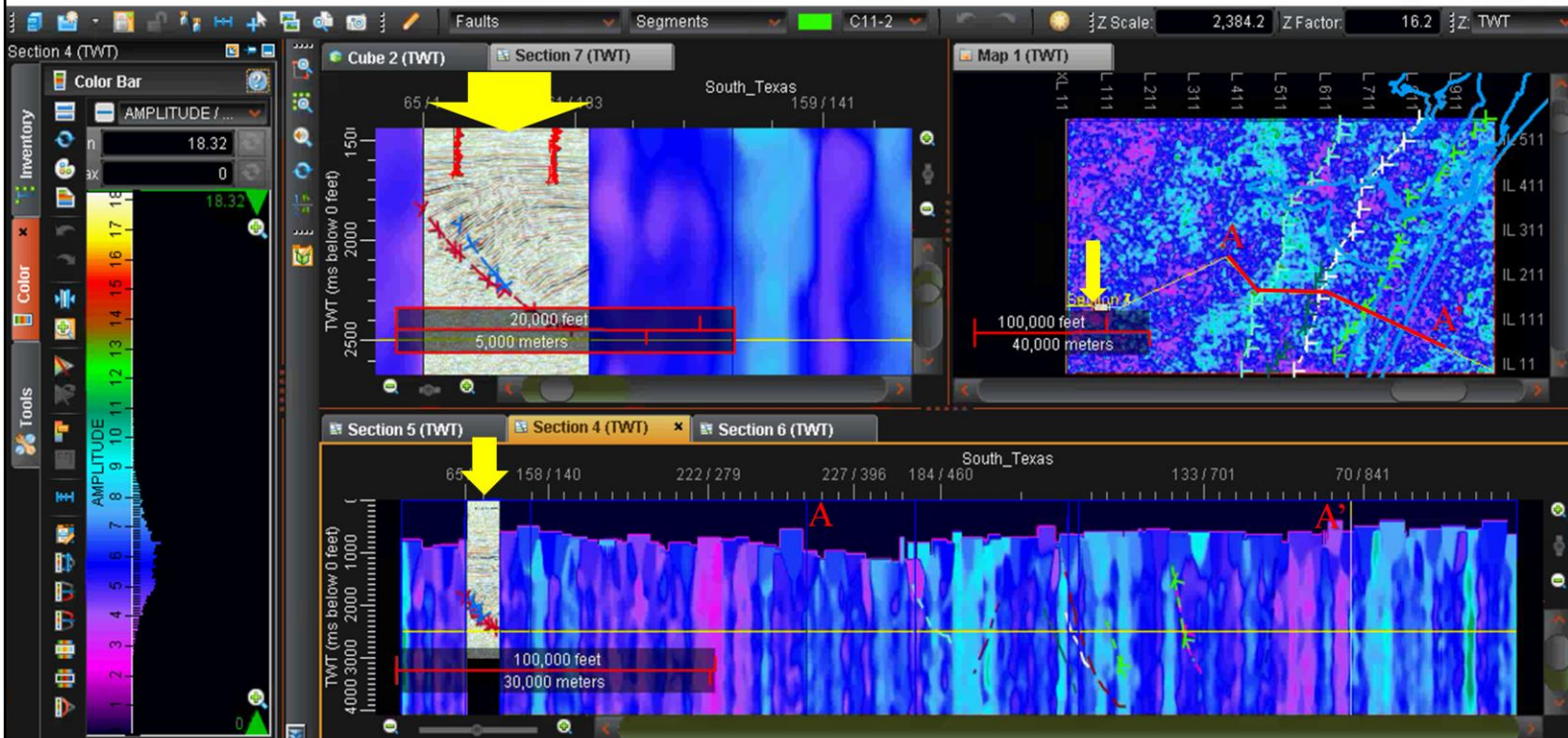

(Strikes per square kilometer)

04 October 2016

Copyright © 2016
Dynamic Measurement LLC.

Presenter's notes: The first of these lightning attributes is density. Lightning density is calculated by counting the number of lightning strikes in a cell of a specified size. Assigning the number of lightning strikes in each cell (trace location) to the depths estimated from the Peak Current, and doing a 3-D interpolation between all resulting points in 3-D space, creates a density volume. The resulting volume has vertical striping, because it is based on the number of strikes at a location. Units are strikes per area, where the default area is in square kilometers.

2 of 18 Lightning Attributes - Day of Year

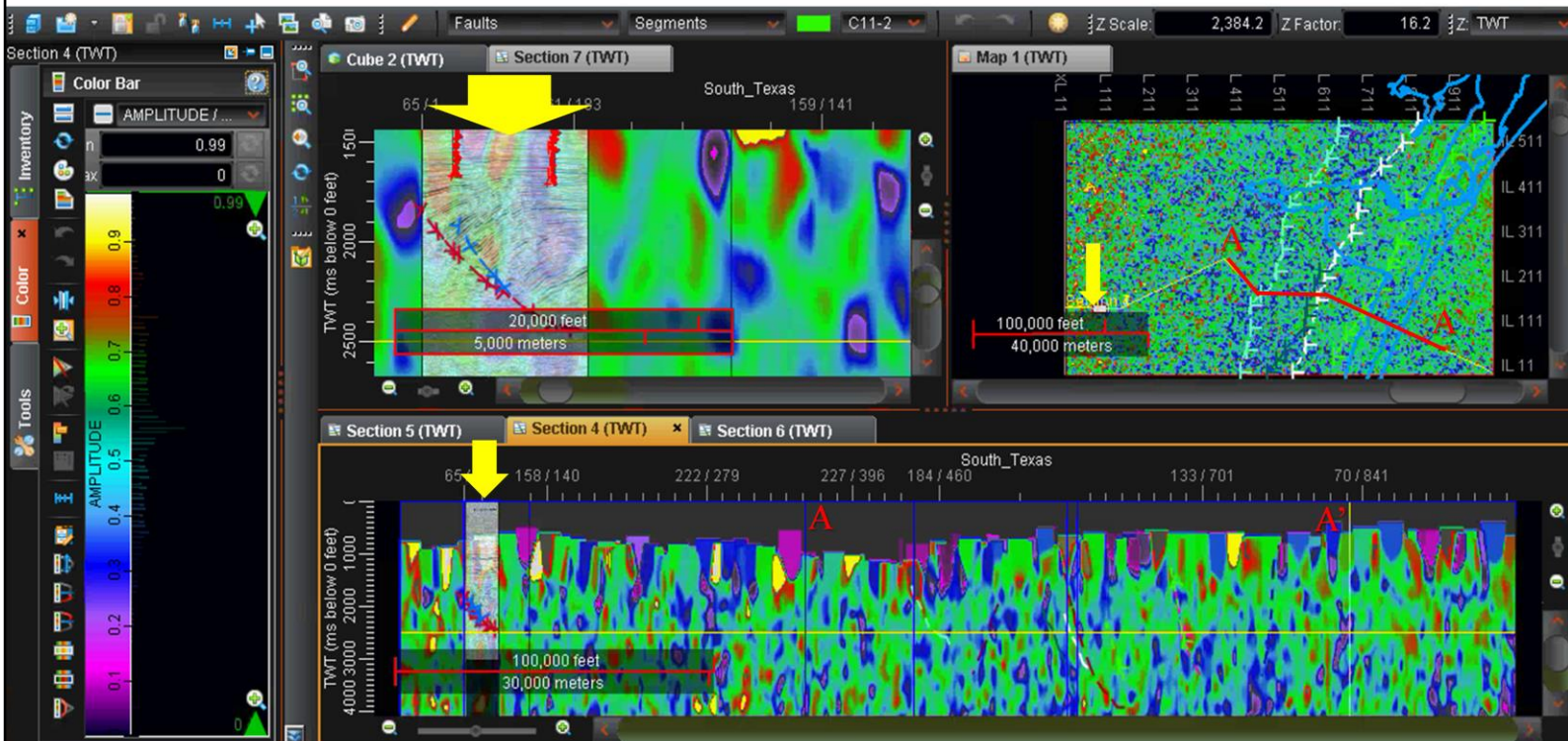

(Decimal fraction calendar year)

04 October 2016

Copyright © 2016
Dynamic Measurement LLC.

Presenter's notes: Because we know the time of each lightning strike to the nearest microsecond, we know the day of the year the lightning strike occurred. Day of year is also related to season, and when storms are likely to happen in a specific area. The units follow a calendar year and range from 00:00 on Jan 1 = 0.0, to 24:00 on Dec 31 = 1.0. This is defining more of a meteorological effect than a geological effect. Placing this value in each cell (trace location) at the depths estimated from the Peak Current, and doing a 3-D interpolation between all resulting points in 3-D space, creates a Day-of-Year volume. Note that Dynamic Measurement is developing a method for using this newly identified geophysical data type of lightning databases, and we have not yet defined the significance and exploration value, if any, of each of the derived attributes. Also, note that the color bars are arbitrary, though based on experience working with seismic attributes. The Day-of-Year scale is a decimal fraction of the calendar year at the instant of each lightning strike.

3 of 18 Lightning Attributes - Energy

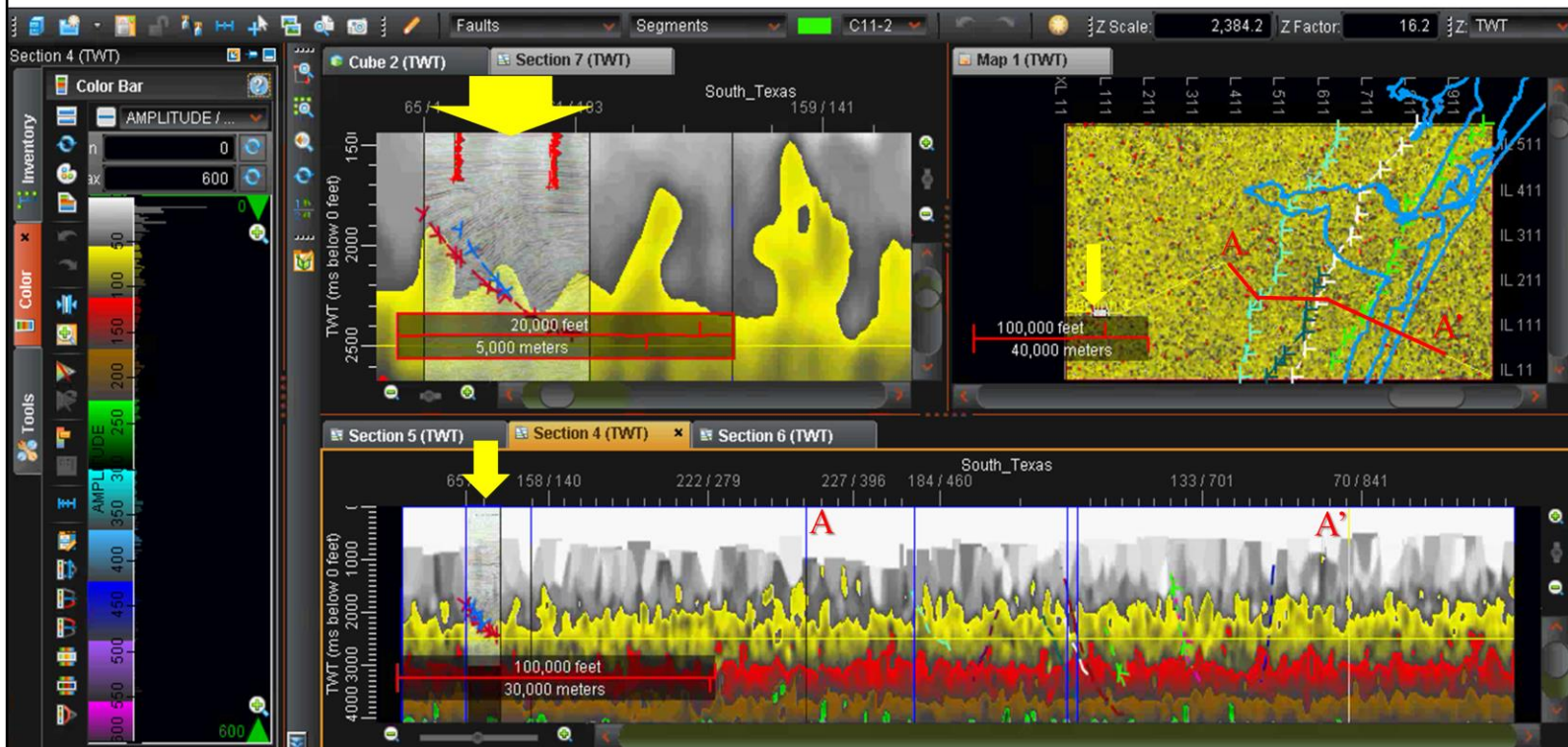

(milliampere-seconds)

04 October 2016

Copyright © 2016
Dynamic Measurement LLC.

Presenter's notes: The Energy Attribute volume is determined by calculating the area under the curve defined by zero to Peak Current across the measured Rise-Time and Peak Current to zero across the measured Peak-to-Zero: $[(pc * (rt + pz)/2)]$ milliampere-seconds. As expected, the deeper the values the larger the lightning-derived energy values. This is because it takes more energy to bridge a larger atmospheric dielectric and capture deeper information. The units for this lightning attribute are milliampere-seconds, and range from 0 to 600 milliampere-seconds for this data set in South Texas. This same attribute ranges from 0 to 1,000 milliampere-seconds in a desert in California.

4 of 18 Lightning Attributes - Frequency

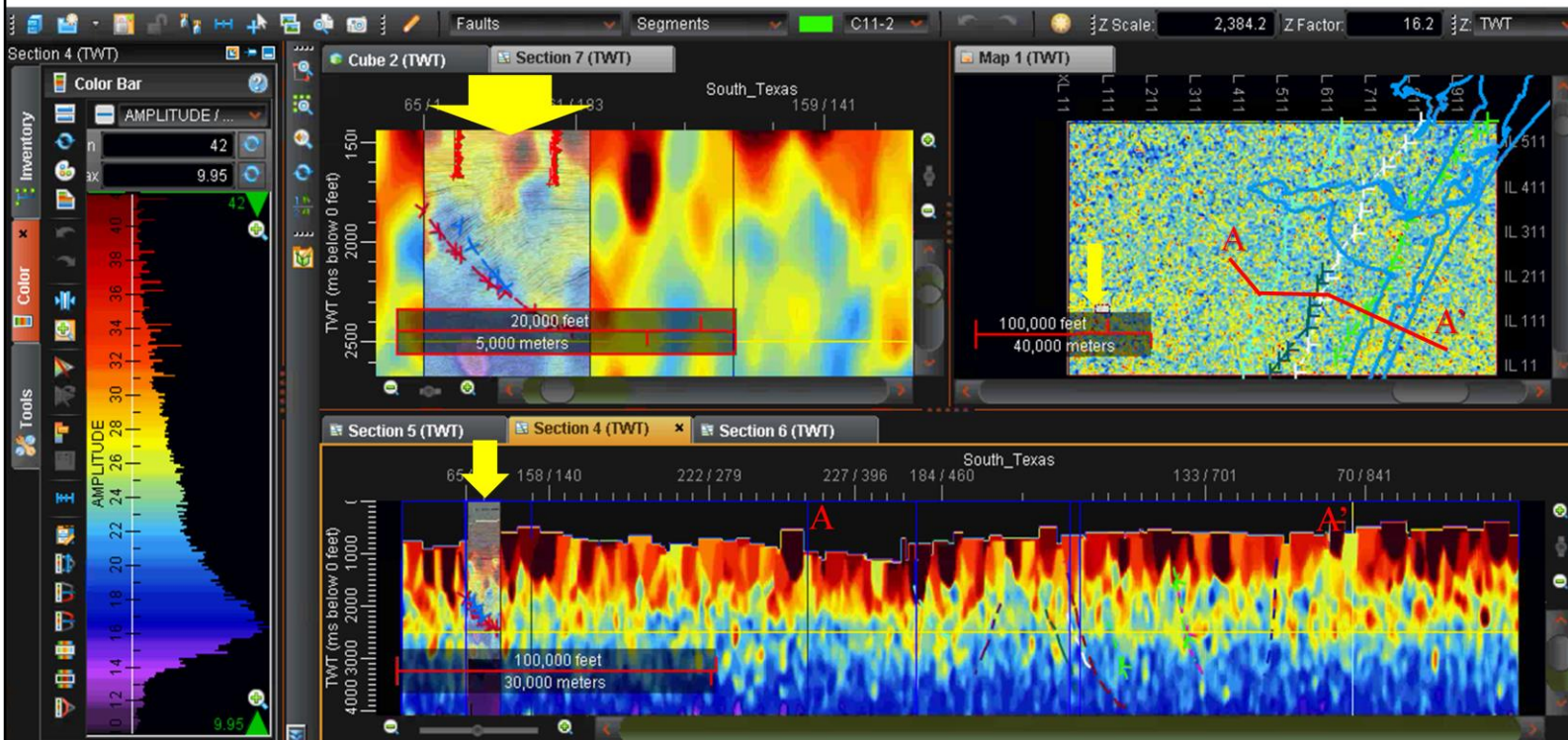

(kilohertz)

04 October 2016

Copyright © 2016
Dynamic Measurement LLC.

Presenter's notes: The frequency attribute is derived by calculating the inverse of the wavelength ($1/[\text{Rise-Time} + \text{Peak-to-Zero_Time}]$). This is the dominant frequency of the lightning pulse (kilohertz). The color bar selected is the color bar SeiscomDelta first used to display the Instantaneous Frequency seismic attribute. Note on the upper left section there is a low frequency anomaly corresponding to the faults interpreted on seismic data.

5 of 18 Lightning Attributes - Moon Local Longitude

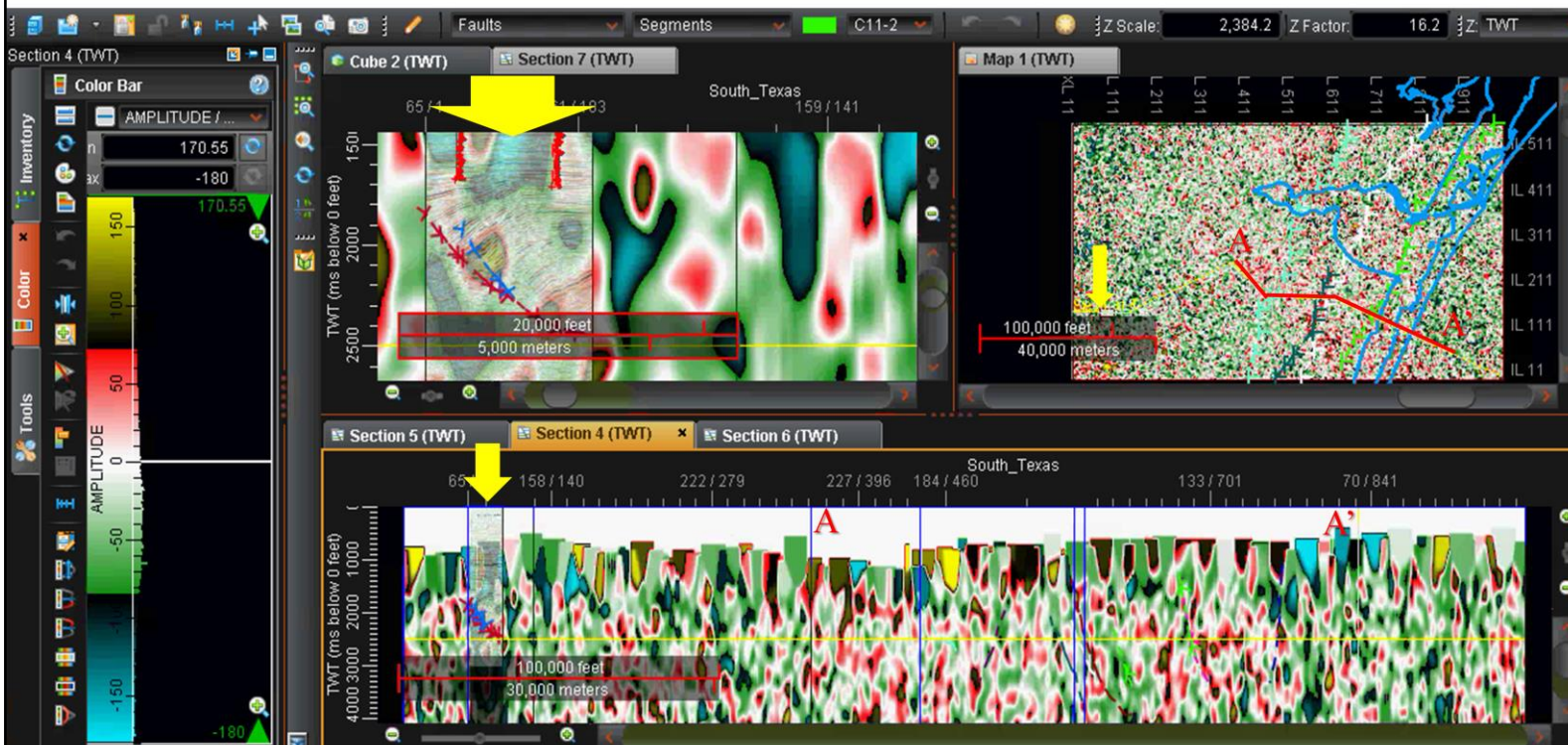

(degrees [-180 to 180]s)

04 October 2016

Copyright © 2016
Dynamic Measurement LLC.

Presenter's notes: The Moon Local Longitude Attribute is a measure of the longitude of the moon relative to the longitude of the strike, and is scaled in degrees (-180 to 180). Note the anomaly on the up-thrown side of the fault, and the interesting anomaly in the Vicksburg expansion downthrown to the fault on the Stratton seismic section.

6 of 18 Lightning Attributes - Moon Phase

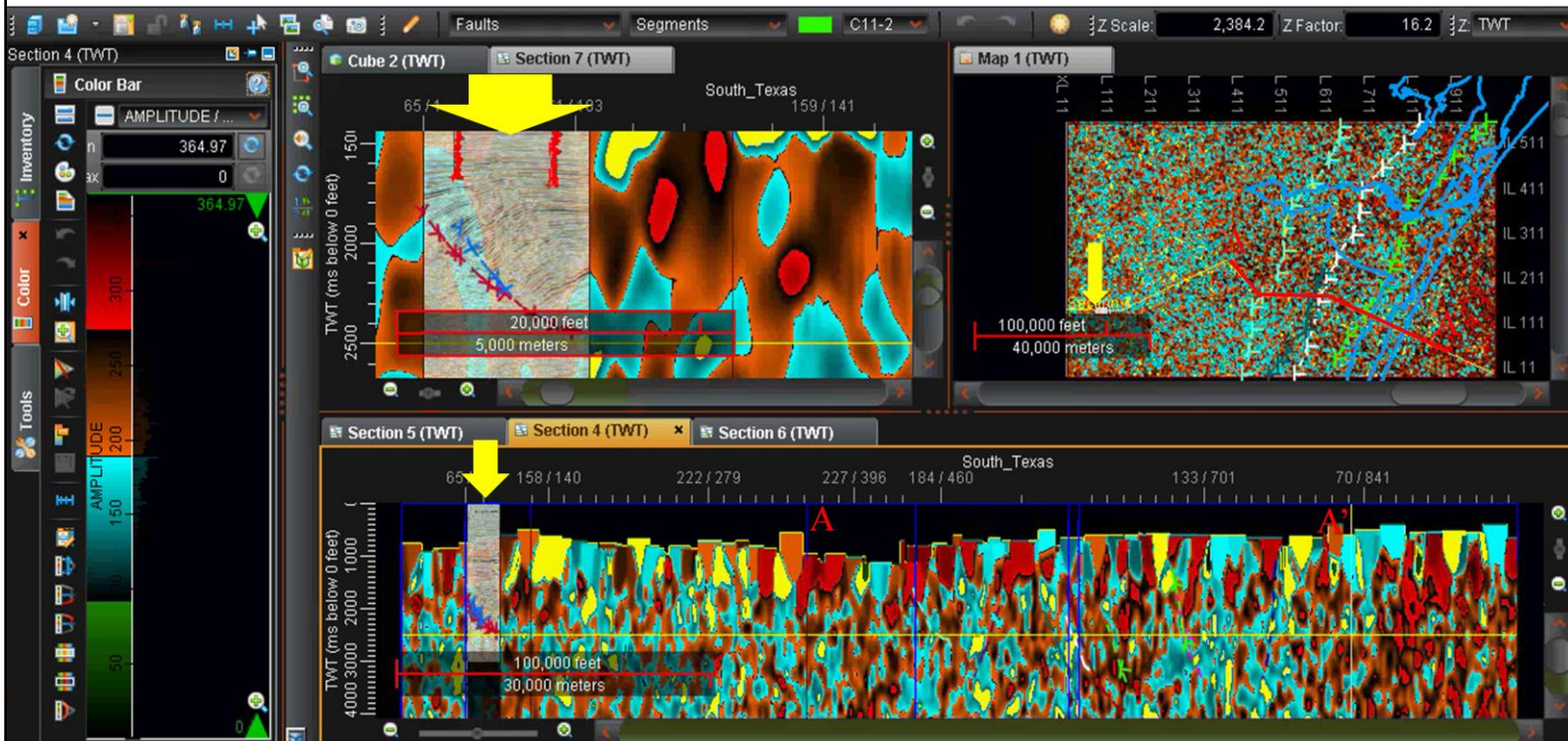

(degrees [0-360])

04 October 2016

Copyright © 2016
Dynamic Measurement LLC.

Presenter's notes: This lightning attribute captures the phase of the moon at the instant of the strike, places this value at the depth determined from the Peak Current, and then interpolates in three dimensions. Moon Phase scale is in degrees (0-360). Dynamic Measurement started looking at the relationships between lunar tides and lightning strikes when we realized there were 25% more lightning strikes at high lunar tide across the Nesson Anticline in North Dakota, compared to the number of lightning strikes at low lunar tide.

7 of 18 Lightning Attributes - Peak to Zero

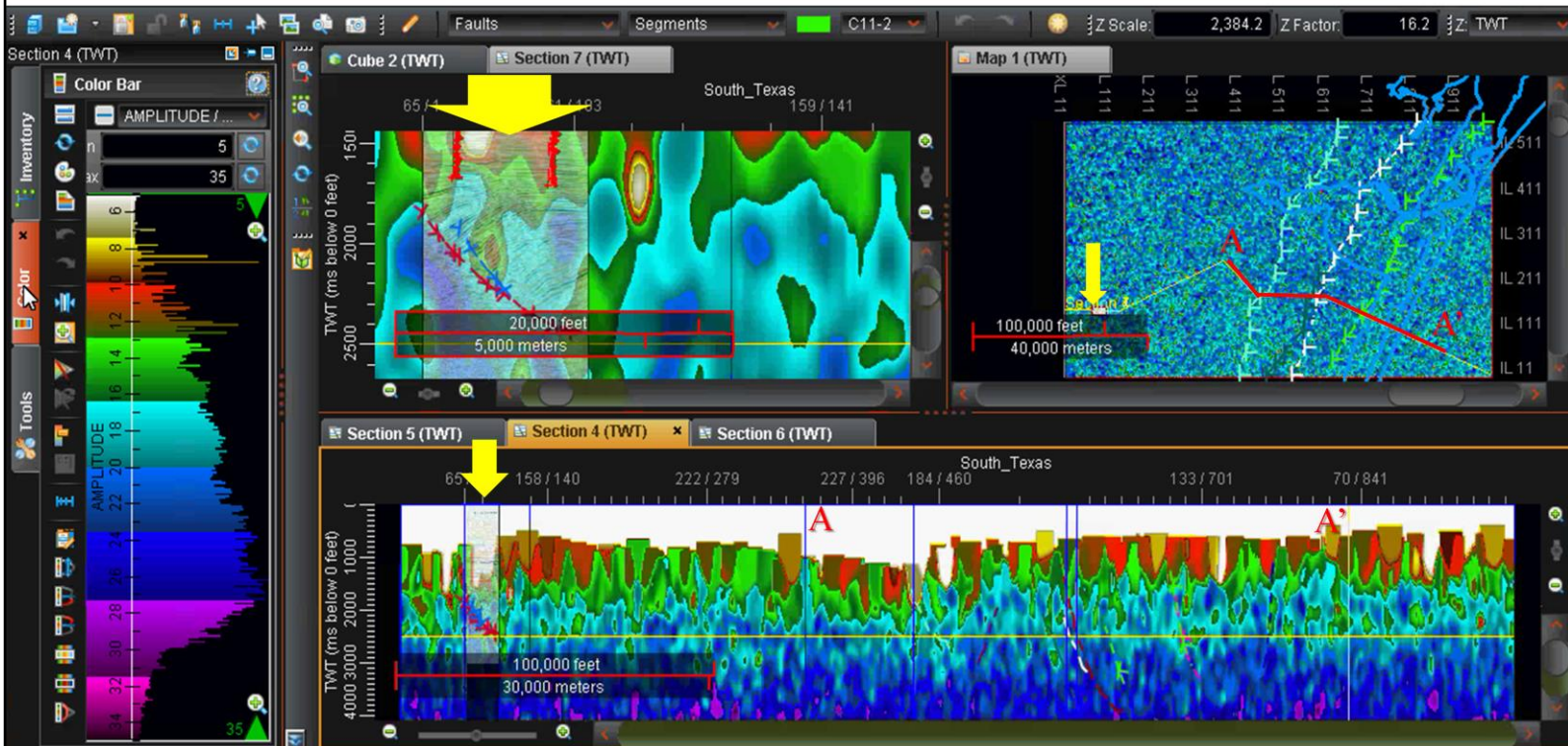

(microseconds)

04 October 2016

Copyright © 2016
Dynamic Measurement LLC.

Presenter's notes: Peak-to-Zero is the average time in microseconds from the time of Peak Current to the time when the current returns to the background electrical noise. This is calculated within each cell at specific depths, and interpolated to create a 3-D volume. Peak-to-Zero time is measured in microseconds. There are similarities with these cross-sections and those from Moon Local Longitude, Rise-Time, Peak-to-Zero, and Total-Wavelet Time. Dynamic Measurement is studying the relationship and the correlation between different lightning attributes.

8 of 18 Lightning Attributes - Peak Current

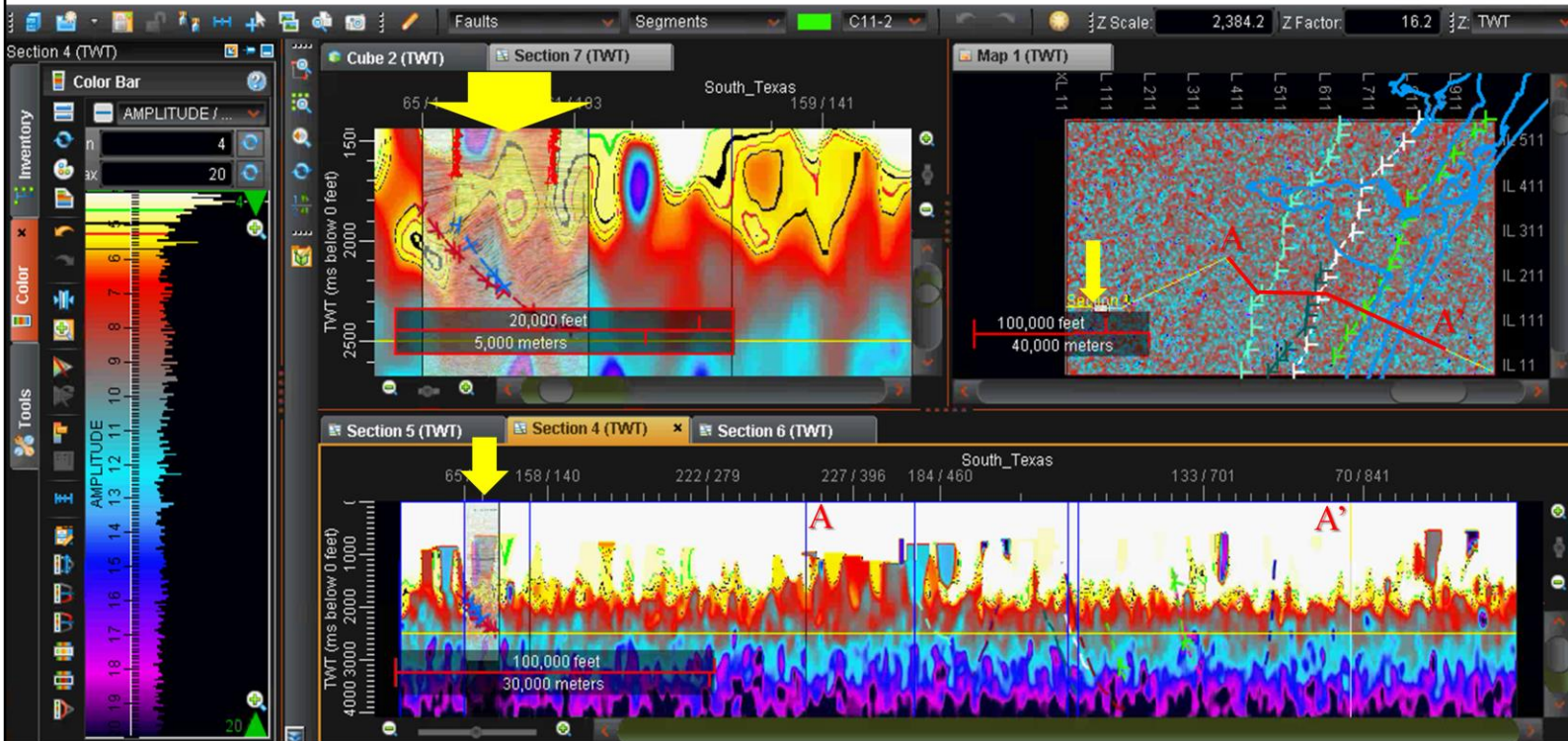

(kiloamperes)

04 October 2016

Copyright © 2016
Dynamic Measurement LLC.

Presenter's notes: The absolute value for all strikes (kiloamperes) were binned, averaged, posted at their calculated depth, interpolated, turned into a SEG-Y volume, and loaded into Landmark Graphics' Decision Space Geoscience (DSG) software package. The color scale selected was very smooth, so markers were placed in the color scale to highlight differences. The relationship with the picked faults across the Stratton survey in the upper left display is very compelling.

9 of 18 Lightning Attributes - Apparent Permittivity

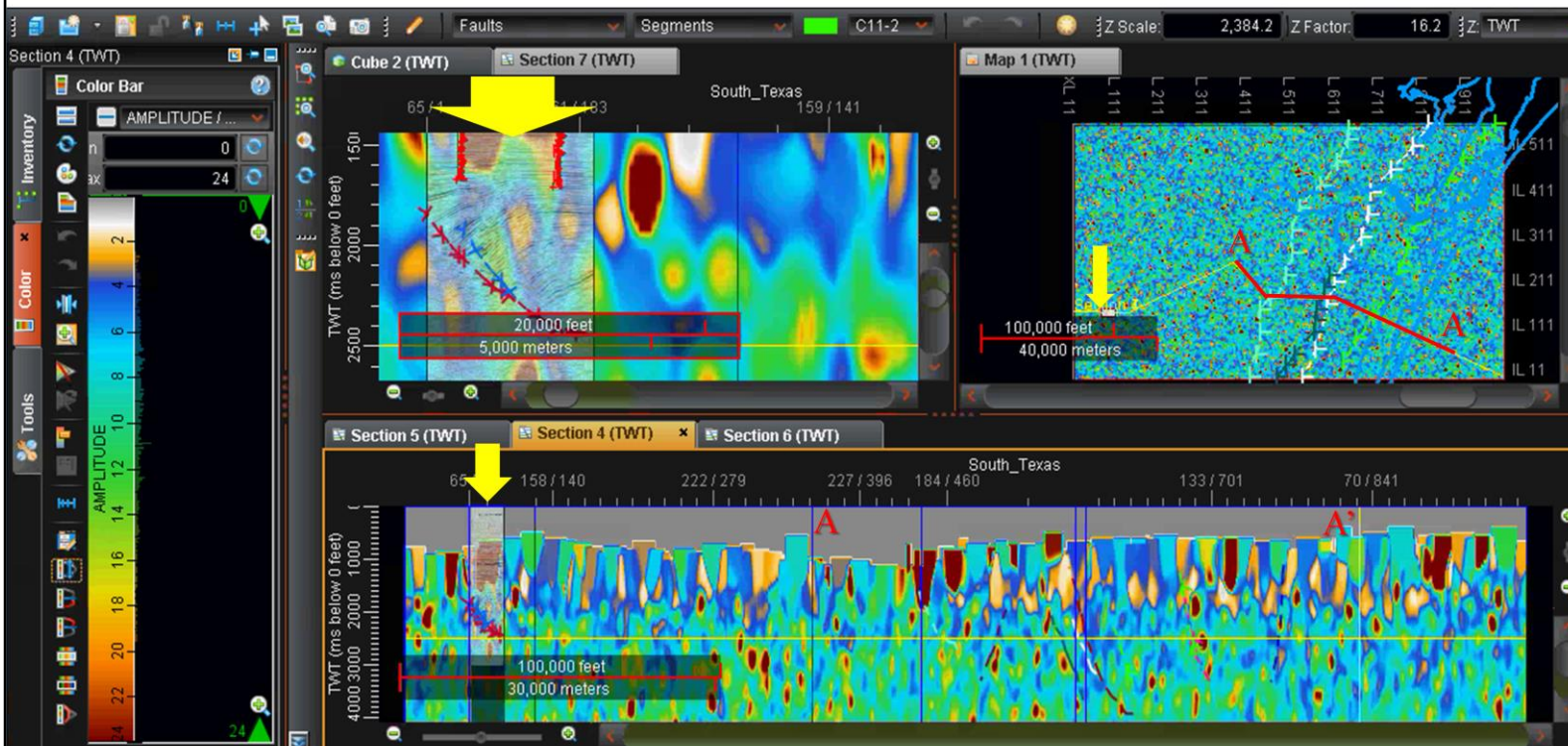

(microfarads per meter)

04 October 2016

Copyright © 2016
Dynamic Measurement LLC.

Presenter's notes: The distributed capacitance of an earth volume computed from Rise-Time and Peak Current. Usually supplied only as a volume, the Apparent Permittivity scale is in microfarads per meter. This is one of two rock property volumes calculated from the lightning database. Again, note how well the Stratton faults are imaged by this lightning attribute.

10 of 18 Lightning Attributes - Apparent Resistivity

Used to correlate Ewing's 1986 cross-sections

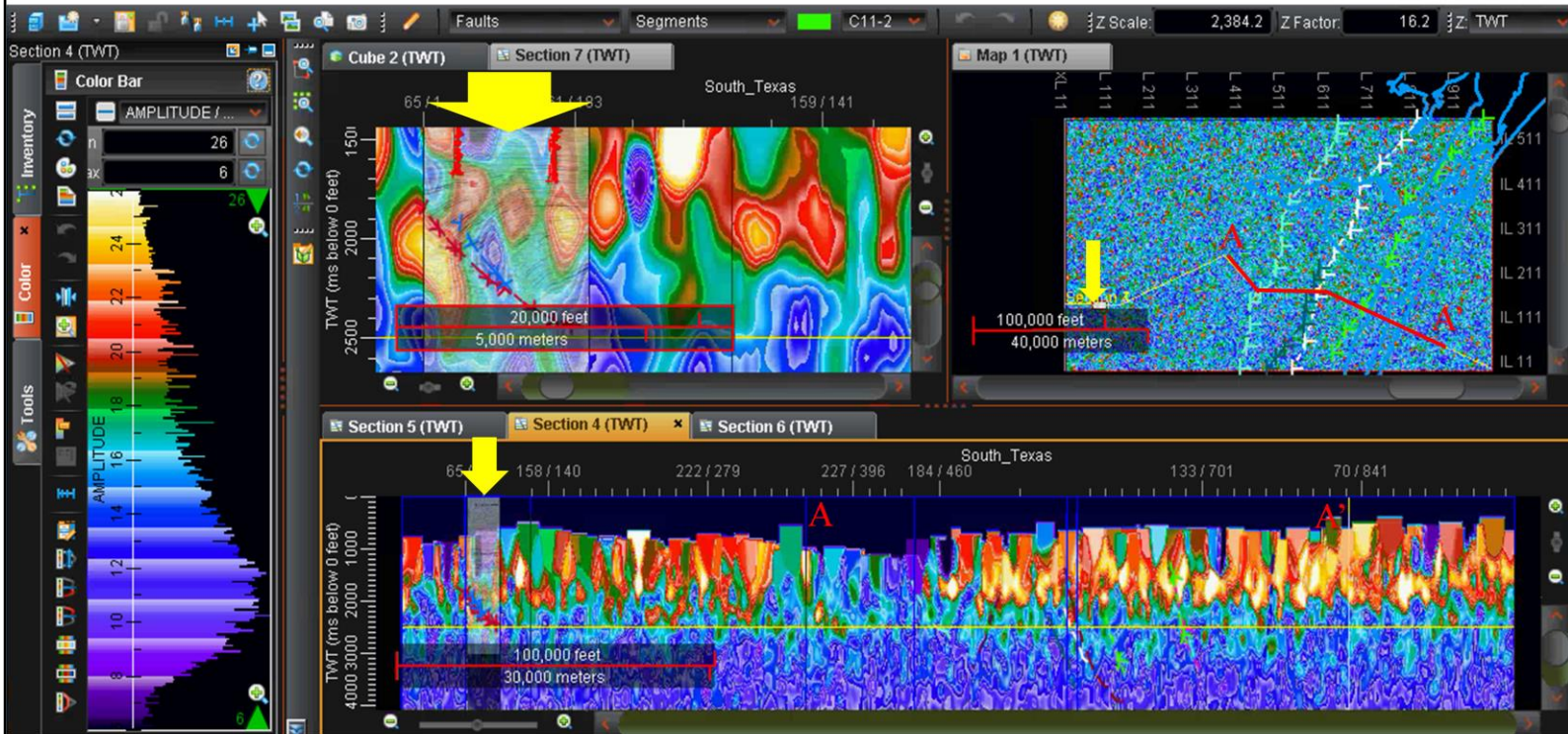

(ohm-meters)

04 October 2016

Copyright © 2016
Dynamic Measurement LLC.

Presenter's notes: Having looked at nine other lightning-derived attributes, this display goes back to the apparent-resistivity display, which set up this section of slides. The electrical resistivity and depth are computed from a simple model using the Peak Current and Peak-to-Zero time. As with apparent permittivity, this rock property attribute is usually supplied only as a volume. The Apparent Resistivity scale is in ohm-meters, and Dynamic Measurement is working to better calibrate these calculations with the resistivity measurements in well log data.

11 of 18 Lightning Attributes - Rise Time

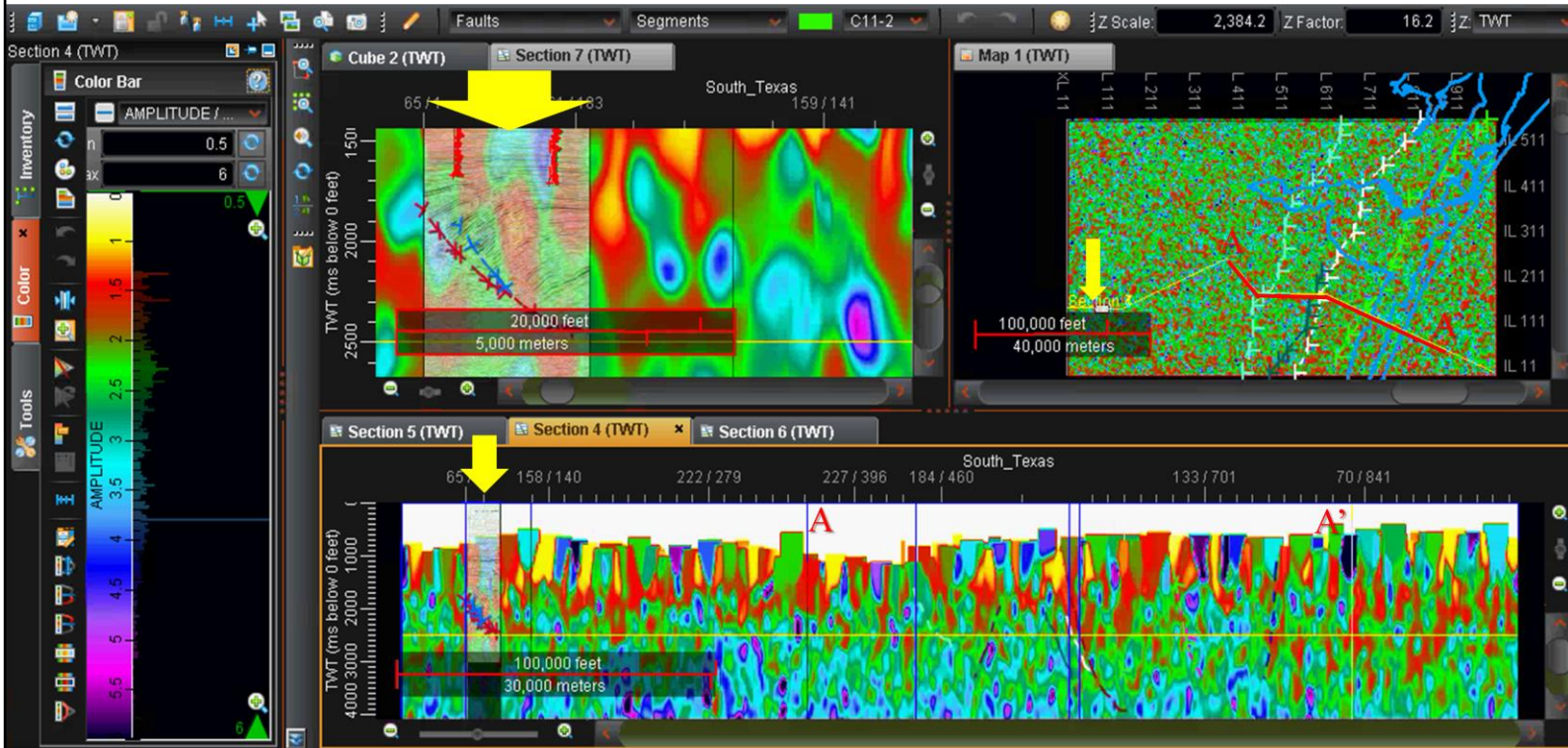

(microseconds)

04 October 2016

Copyright © 2016
Dynamic Measurement LLC.

Presenter's notes: Rise-Time of the strike in microseconds is one of the basic measurements in the lightning database. A standard product has a map, as an XYZ file, and a volume. The Rise-Time scale is in microseconds, which is the time it takes to go from background electrical noise to Peak Current in microseconds, averaged over each cell in the project data volume.

12 of 18 Lightning Attributes - Spike

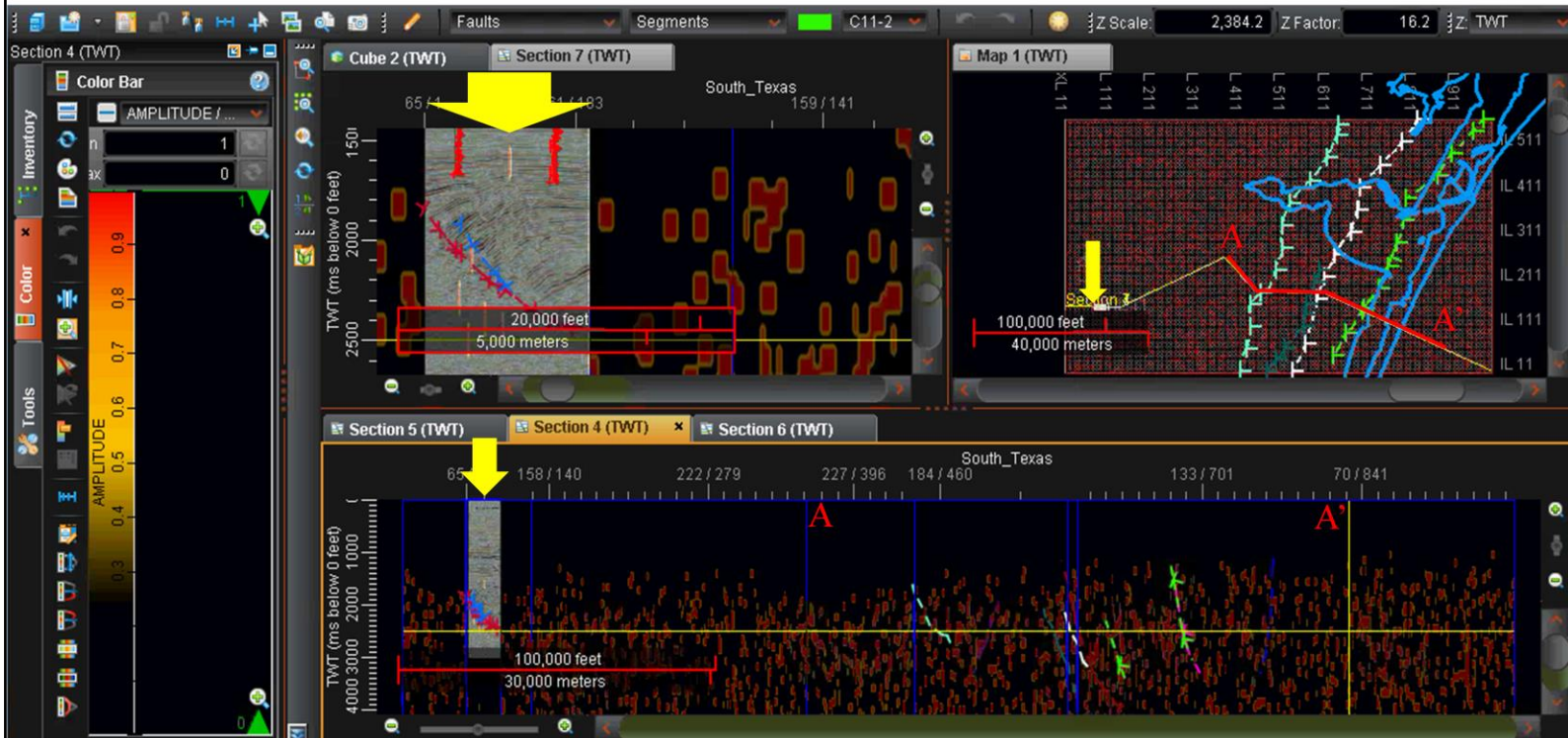

(position of strike)

04 October 2016

Copyright © 2016
Dynamic Measurement LLC.

Presenter's notes: The spike volume gives a depth value from Peak Current to the location of each strike. This display shows the depth location of each lightning strike that falls right along the lines or the time-slice cross-section. Note, there are strikes on adjacent lines, which are interpolated in three-dimensional space to create the differences seen on these various lightning-database-derived rock property and lightning attribute volumes.

13 of 18 Lightning Attributes - Sun Local Longitude

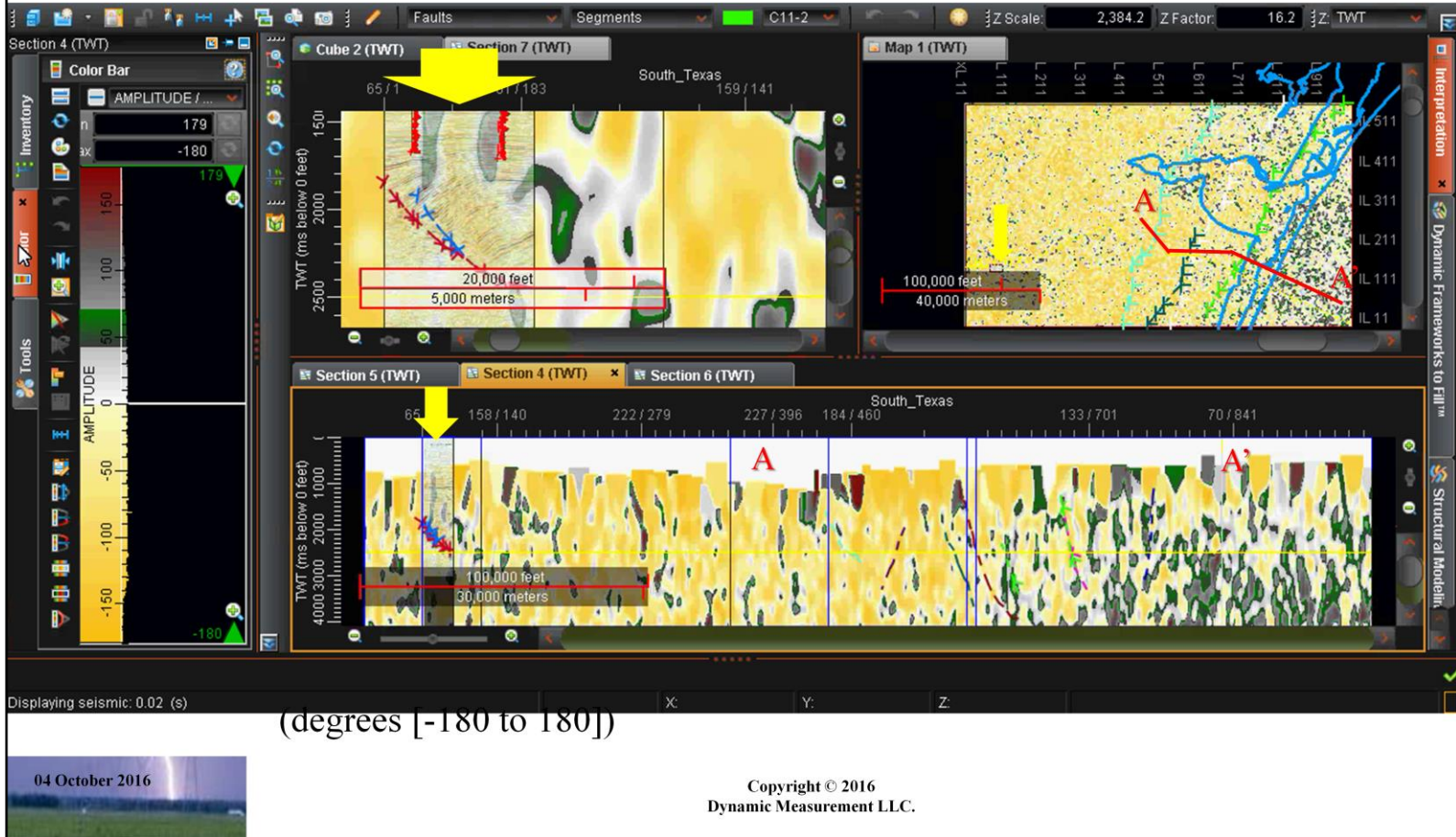

(degrees [-180 to 180])

04 October 2016

Copyright © 2016
Dynamic Measurement LLC.

Presenter's notes: The solar equivalent to Moon Local Longitude Attribute is a measure of the longitude of the sun relative to the longitude of the strike, and is scaled in degrees (-180 to 180). Note that there is a significant difference in the time-slice off the coast on this particular lightning-derived attribute. As with any large raw data volume, there are many things yet to be learned from the various lightning attribute volumes relative to their relationship to the geology.

14 of 18 Lightning Attributes - Symmetry

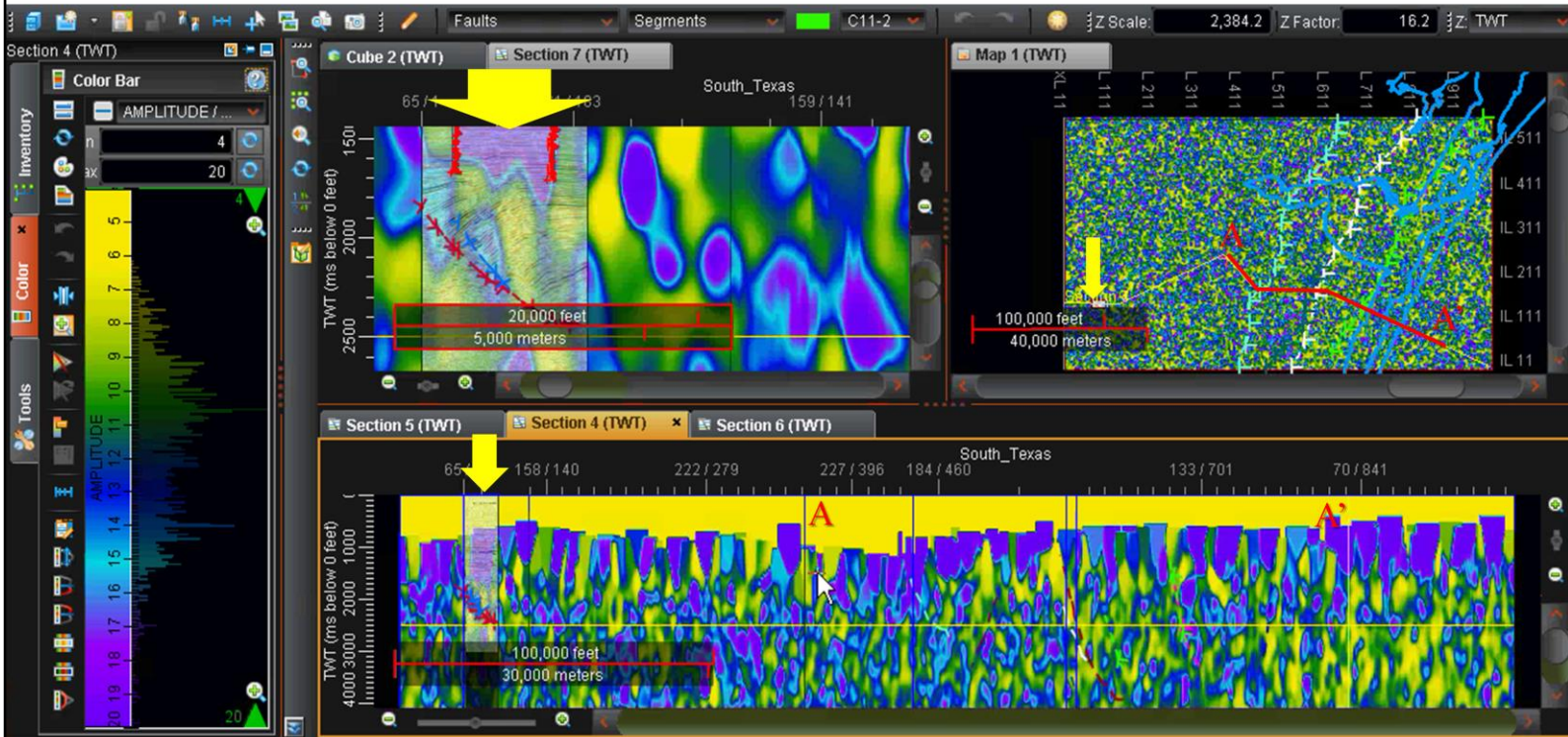

(% [<50: rt<pz; 50: rt=pz; >50: rt>pz])

04 October 2016



Copyright © 2016
Dynamic Measurement LLC.

Presenter's notes: Symmetry of the strike pulse is defined by $100 * [\text{Rise time}] / [\text{Total time}]$ and is available as a map, an XYZ file, and a volume. The Symmetry scale is a percentage (% [<50: rt<pz; 50: rt=pz; >50: rt>pz]), and is the ratio of Rise-Time to Total-Wavelet Time. Wavelet Symmetry is inversely related to its Peak-to-Zero contribution.

15 of 18 Lightning Attributes - Tidal Gravity

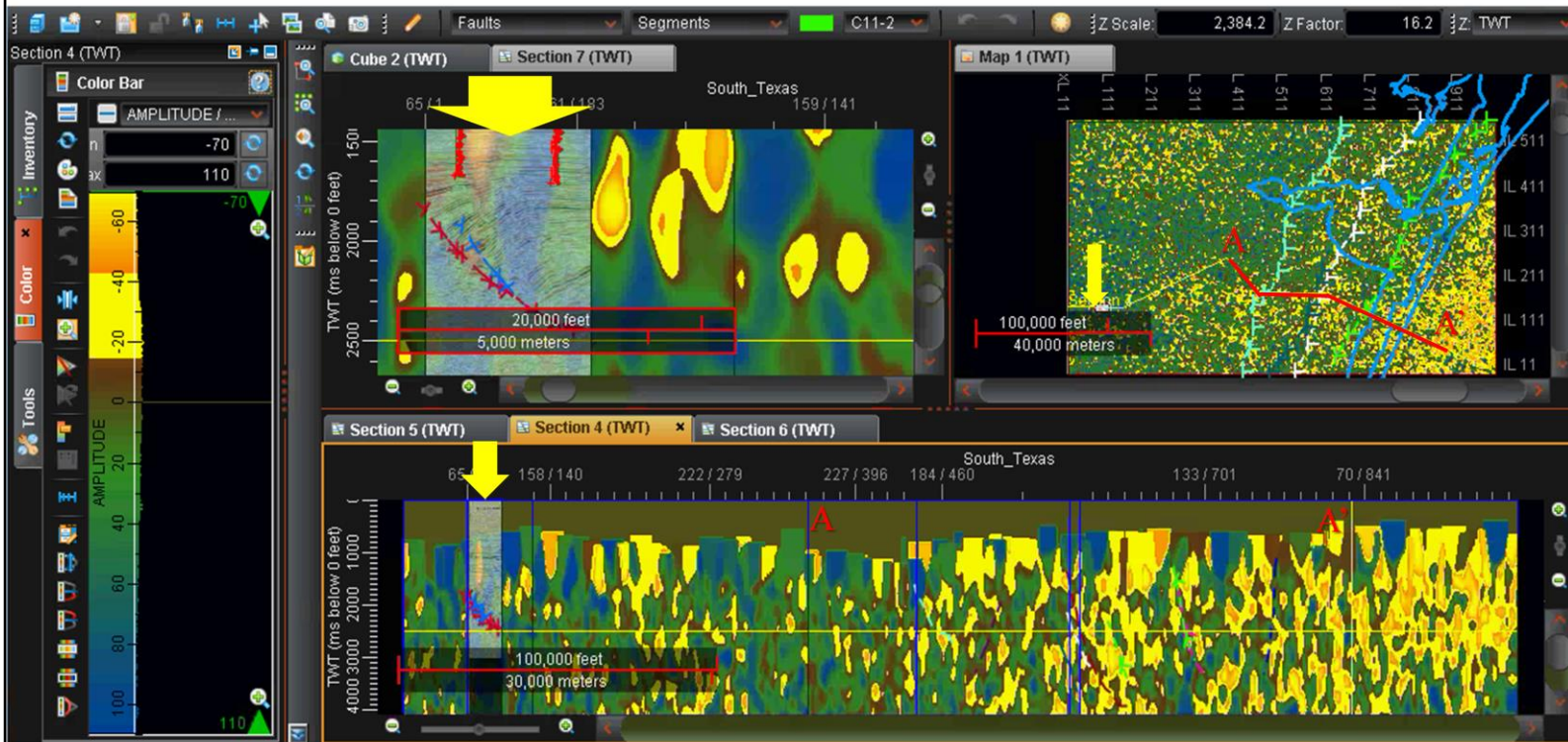

(microgals)

04 October 2016

Copyright © 2016
Dynamic Measurement LLC.

Presenter's notes: This attribute, Tidal Gravity, is determined by calculating the gravitational effect of both the sun and moon at the instant and the location of the lightning strike as measured in microgals. Results are available as a map, an XYZ file, and a volume. Again, the Tidal Gravity scale is in microgals (+/-, relative to long-term mean).

16 of 18 Lightning Attributes - Tide

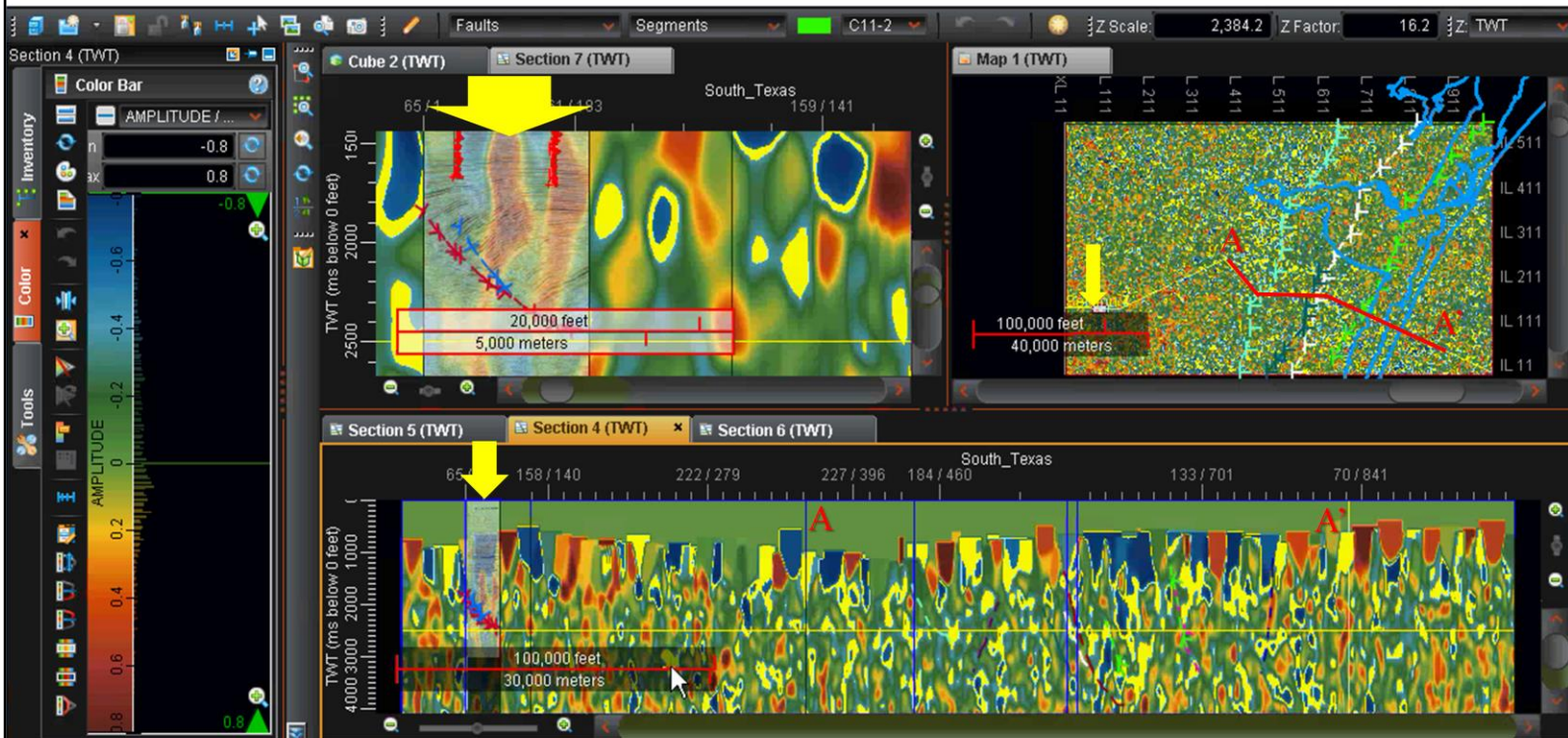

([-1.0: low spring tide; 0.0: mean tide; 1.0: high spring tide])

04 October 2016

Copyright © 2016
Dynamic Measurement LLC.

Presenter's notes: The approximate cumulative tidal effect (the sum of lunar and solar gravity) creates earth tides. There are more lightning strikes at high and low earth tides near faults. Tide scale is a fraction of tidal range [-1.0: low spring tide; 0.0: mean tide; 1.0: high spring tide].

17 of 18 Lightning Attributes - Tide Gradient

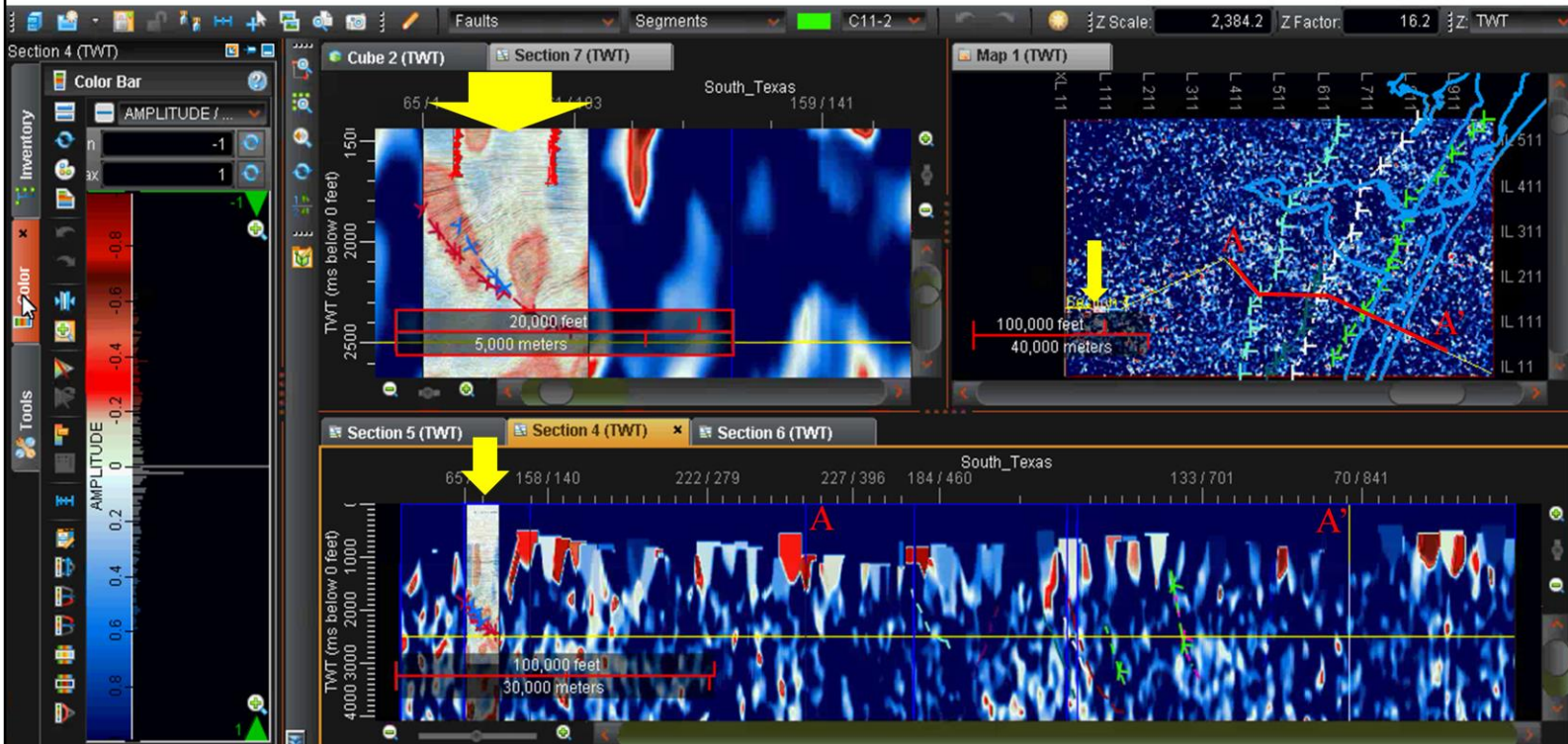

(first derivative of Tide)

04 October 2016

Copyright © 2016
Dynamic Measurement LLC.

Presenter's notes: Earth Tide Gradient is the first derivative of the Earth Tide, or the maximum ebb and flow of the Earth Tide. This attribute is the density of strikes at the tide gradient. There is a definite relationship with the Vicksburg Expansion on the Stratton section in the top left, and a hint at Frio and Oligocene-Pleistocene expansions in the regional section going through A-A' on the bottom. Compare this bottom section to the drawing on slide 17. There is much more work to be done to understand the relationships between these various lightning-derived attributes and geology.

18 of 18 Lightning Attributes - Total-Wavelet Time

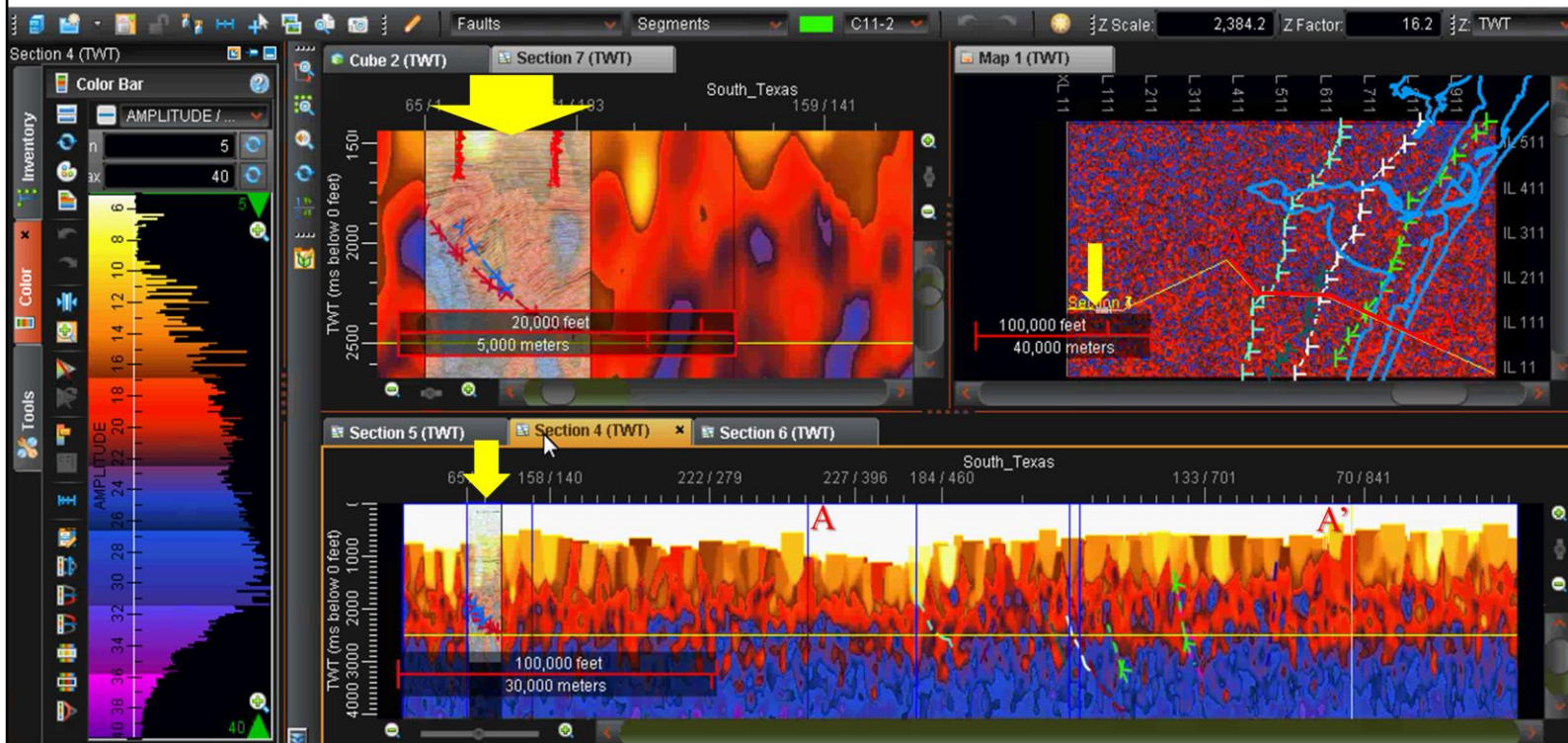

(microseconds)

04 October 2016

Copyright © 2016
Dynamic Measurement LLC.

Presenter's notes: The last attribute shown here, Total-Wavelet Time, is the sum of Rise-Time + Peak-to-Zero Time. The attribute is measured in microseconds, and appears to have a relationship to faulting, as shown with the Stratton seismic data in the upper left display. This 18 slide introduction to lightning-database-derived rock property and lightning attributes introduces a significant new set of data volumes which can be generated anyplace the data is available. In the U.S. and Canada, these volumes can be generated any place out to at least 300 foot water depths. Over the rest of the world, there is the GLD-360 database, which allows creation of 10 of these attributes out to water depths of at least 300 feet. These lightning attribute data volumes provide a new way to evaluate the geology of the world at the surface and from about 4,000 foot to 25,000 foot depths.

5a. Arizona Examples: Resolution Copper

NLDN Peak Current

&

Rise-Rate

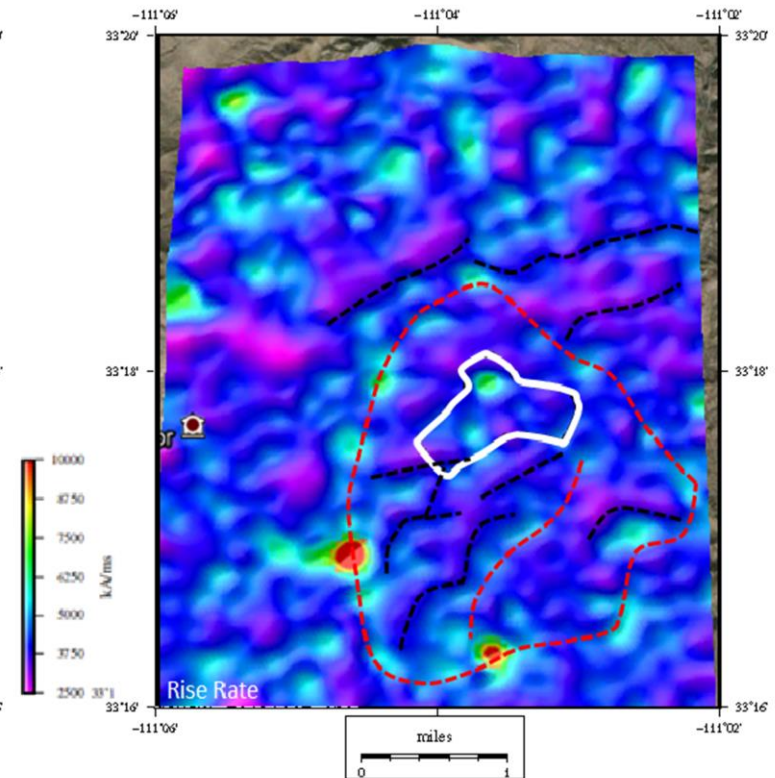
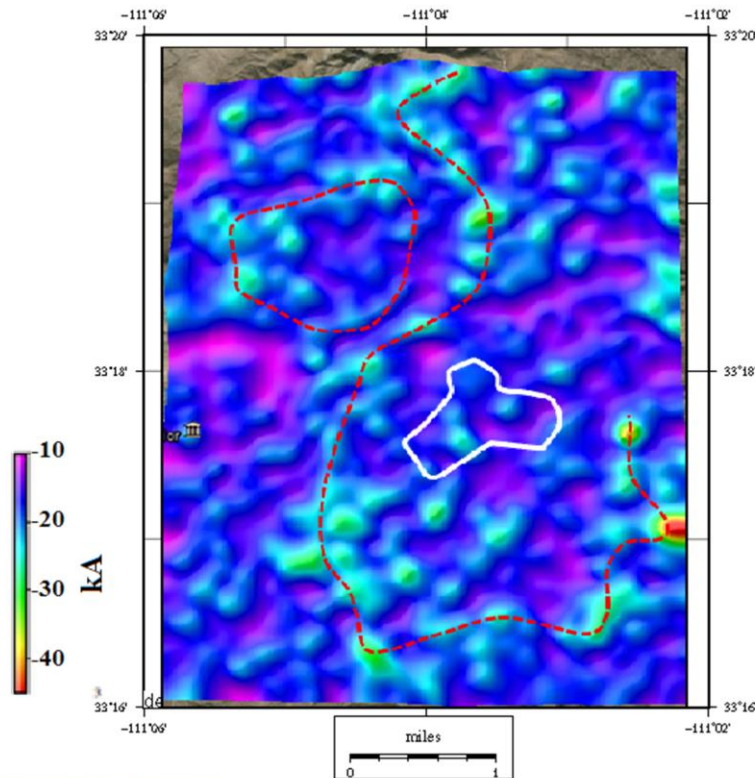

Copyright © 2016
Dynamic Measurement LLC.

Presenter's notes: The last section of this presentation provides a highlight from four lightning analysis projects in Arizona, Louisiana, Michigan, and Texas. This first example shows some lightning-derived map and volume displays across the multi-billion Resolution Copper Mine near Superior, Arizona. These first slide shows maps of NLDN measured Peak Current and derived Rise-Rate. The white structure is the approximate extent of the copper porphyry deposit. The red dashed outline on the two lightning attribute maps shows a halo around this display, and there are interpreted possible volcanic sills through the deposit. Dynamic Measurement will be doing more work with these data volumes and tying the results to ground truth from mining results.

3 Example SPOTSM Apparent-Resistivity Cylinders

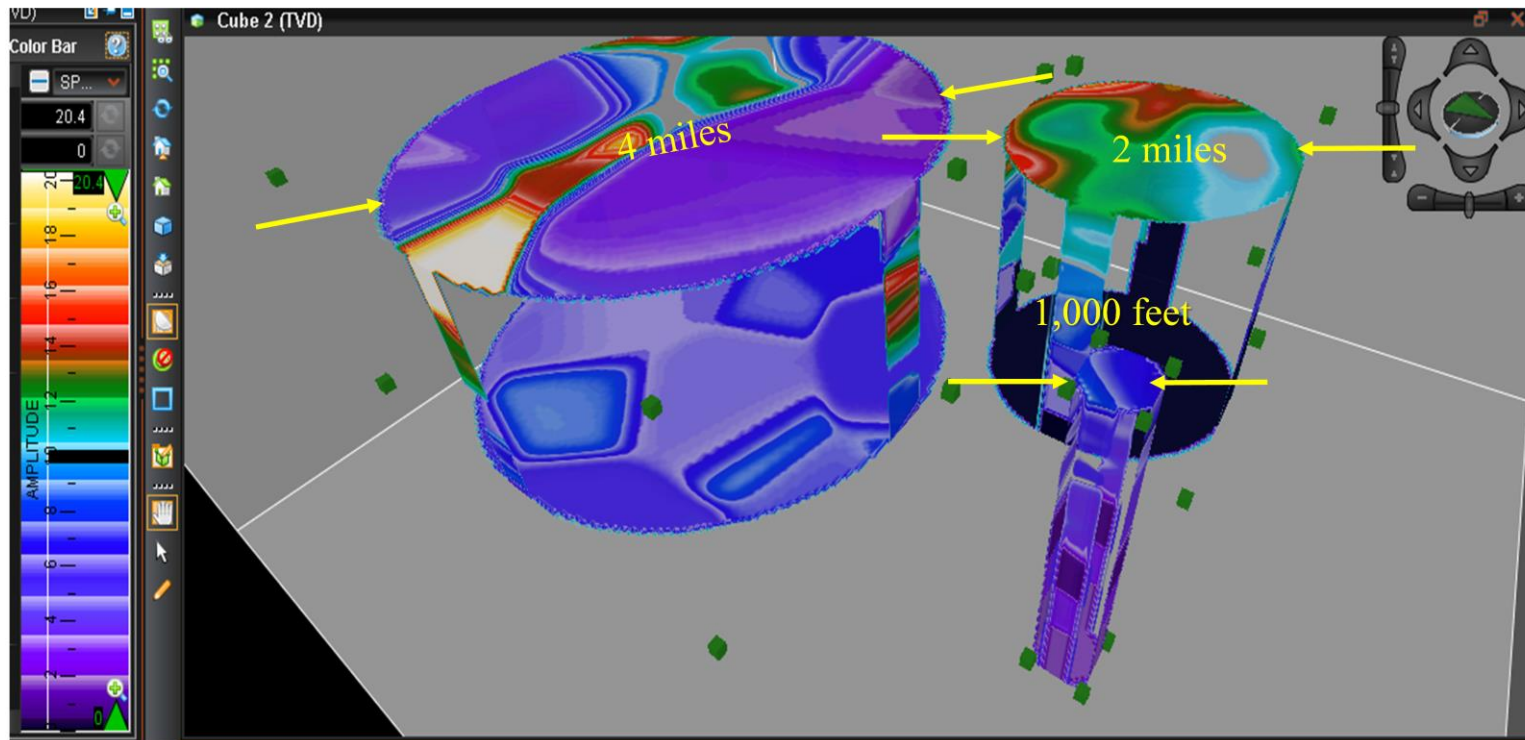

04 October 2016

Copyright © 2016
Dynamic Measurement LLC.

Presenter's notes: One of the new capabilities Dynamic has developed is the ability to create lightning derived "check-shot" surveys, which are named SPOTSM (Strike Position Observation Trend) surveys. SPOTSM surveys can be created any place, quickly and inexpensively. Each survey is defined by a location and a radius out from that radius. These surveys cost 10% of the price of a D.NSEMSM (Dynamic Natural Sourced Electromagnetic Survey) for a 500-foot radius (0.03 square mile) survey, up to about the same price for a 2-mile radius SPOTSM survey. The same lightning-derived rock property and lightning attributes shown in the previous section are generated as circular maps and cylindrical volumes at SPOTSM locations.

Integrating Resistivity in Three-Dimensions

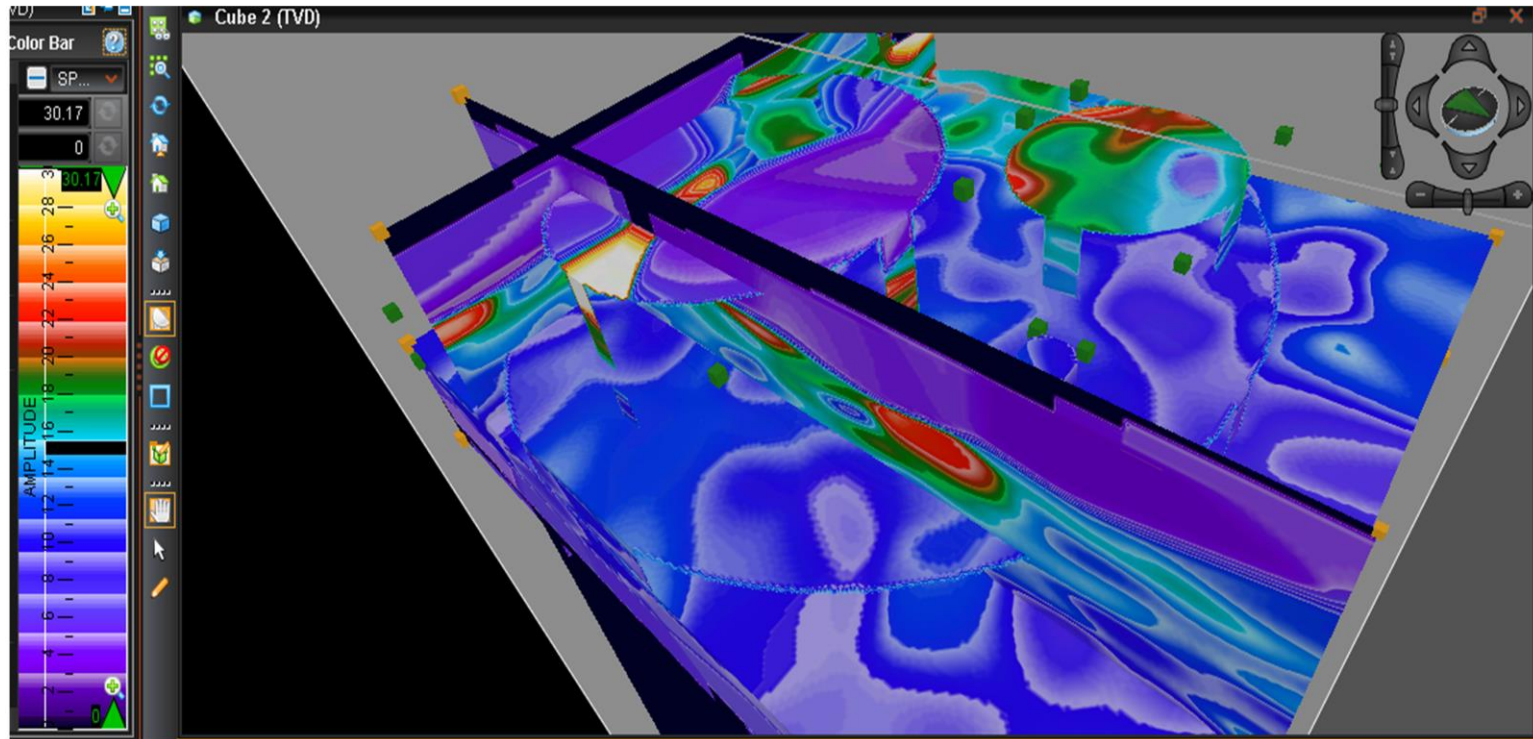

04 October 2016

Copyright © 2016
Dynamic Measurement LLC.

Presenter's notes: SPOTSM Surveys provide an inexpensive way to check out the anticipated lightning attribute response for an area. These surveys can be followed up with a D.NSEMSM survey over the area in order to generate a regional geologic framework, or to tie into existing well logs, gravity, magnetic, magnetotelluric, 2-D seismic, geologic cross-sections, 3-D seismic, 4-D seismic, and other available geological and geophysical control.

Comparing NLDN and GLD-360 data

NLDN Density 1998-2015 & GLD-360 Density 2012-2015

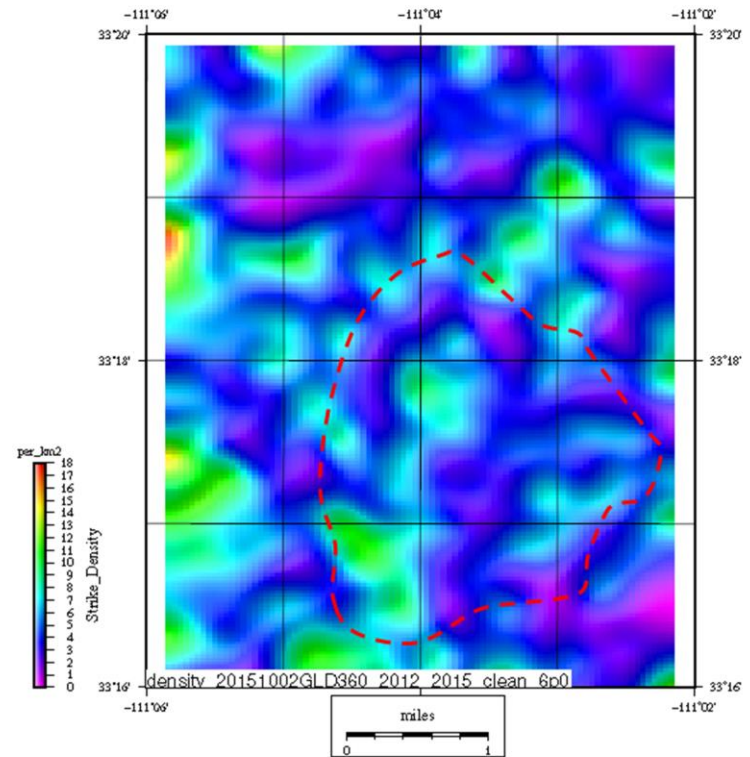
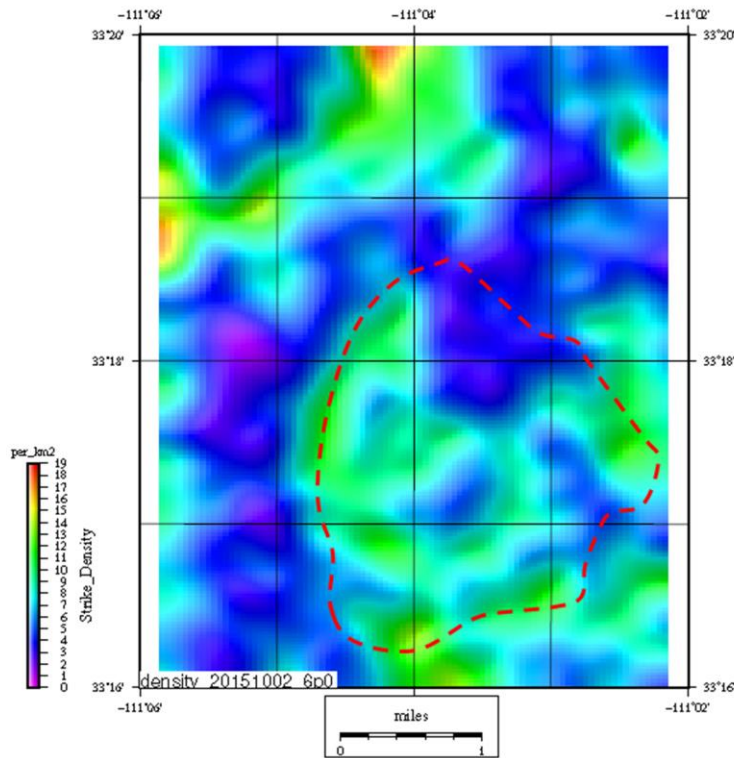

Copyright © 2016
Dynamic Measurement LLC.

Presenter's notes: Dynamic Measurement did a comparison test of NLDN lightning density and GLD-360 density over the same area at Resolution Copper. The results are different, which is to be expected with VLF and LF/VLF sensors. However, the halo is similar from both lightning databases, as shown above. This gives Dynamic Measurement confidence we can accomplish this same type of analysis anywhere in the world out to about 300 foot water depths using the GLD-360 database.

5b. Louisiana Example

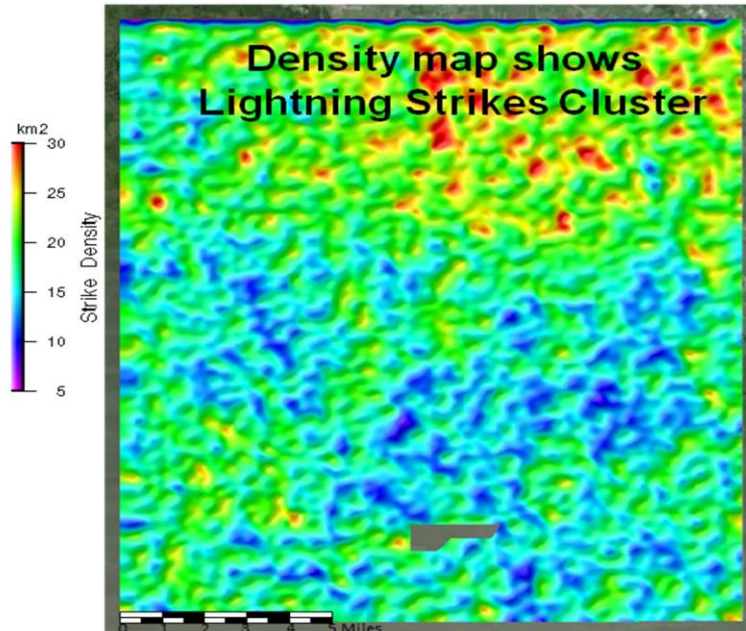

Density Map

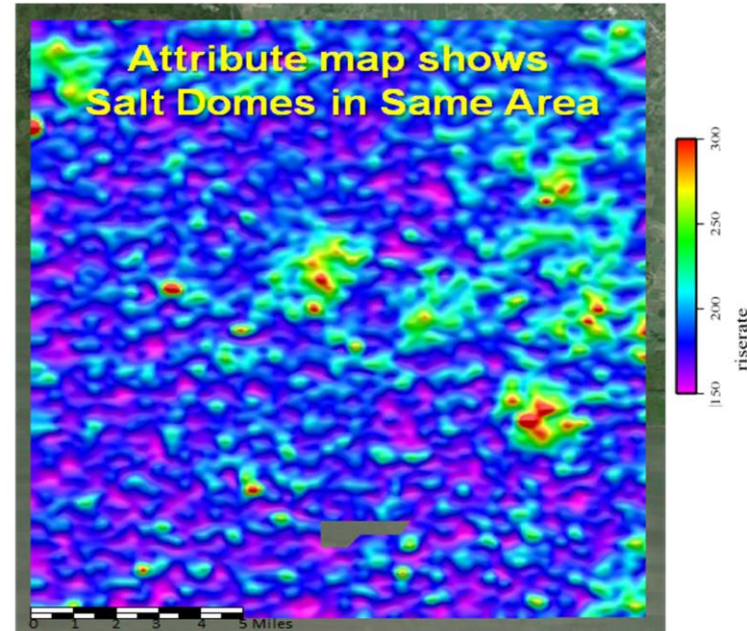

& Rate-of-Rise-Time Map



Copyright © 2016
Dynamic Measurement LLC.

Presenter's notes: This slide is from a lightning analysis project in Iberia Parish, Louisiana. It nicely illustrates how some maps, like Lightning Density on the left show areas of high and low lightning density. There are also lineaments on this map, which relate to fault trends and shallow water. This map is not affected by geology in the same way as the Rate-of-Rise-Time map on the right is. Rate-of-Rise-Time seems to be affected by shallow fresh water, and in this case, by salt domes which come up to the surface. The locations of the three salt domes in this area are very evident on this display, as well as fresh water to the northeast of the two southeast salt domes. Lightning strikes are interacting with geology.

5c. Michigan Example

High Resistivity to SW on B-2 Horizontal-Slice

with Oil & Gas Wells in Analysis Area posted (note lineaments)

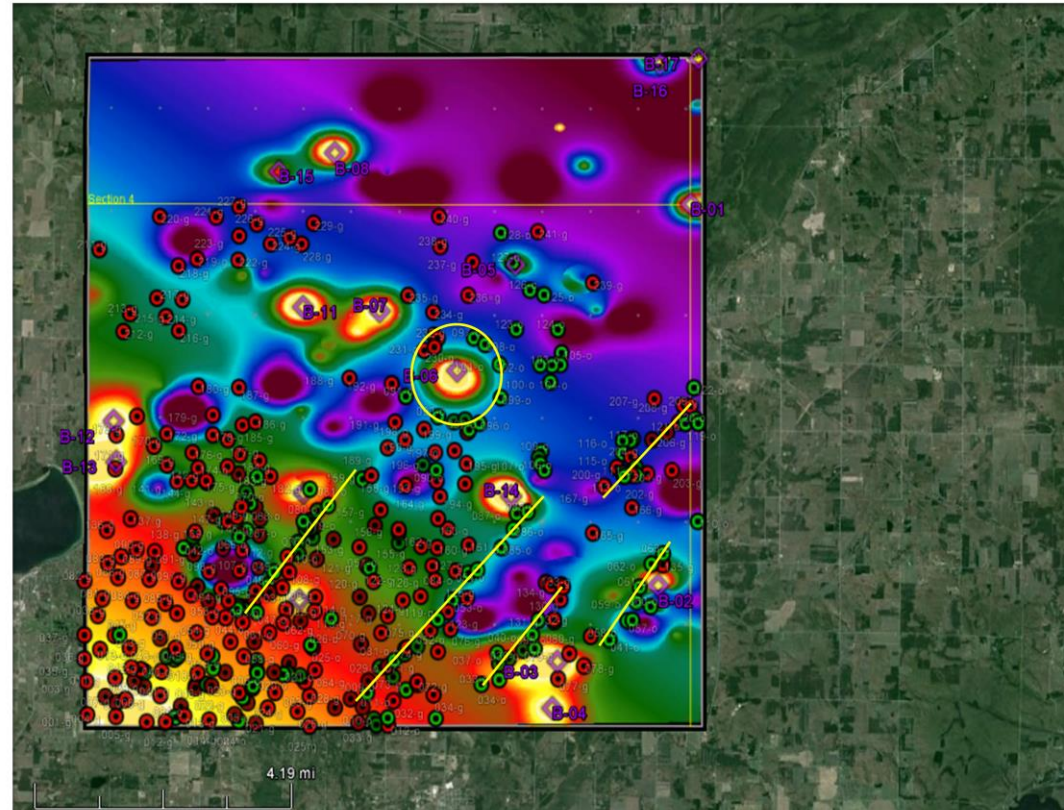

Copyright © 2016
Dynamic Measurement LLC.

Presenter's notes: Lightning analysis response varies by area. This example was put together centered on the MTU cross-hole tomography well test site in the northwest portion of the Michigan Peninsula. The display is a horizontal apparent-resistivity section at about 2800 milliseconds. Wells from the Michigan Geological Survey are overlaid. Red wells are gas wells, which are located where the highest resistivities (reds and yellows) are on the time-slice section. Oil wells fall along lineaments and around one of the circular resistivity anomalies, as noted with the yellow interpretations. Dynamic Measurement needs to get the well logs, and to work on calibrating the vertical axes of the apparent-resistivity volume as well as the calculated apparent-resistivity values with the resistivity values on available well logs. This is part of the ongoing work of a startup operation.

5d. One Last Texas Example

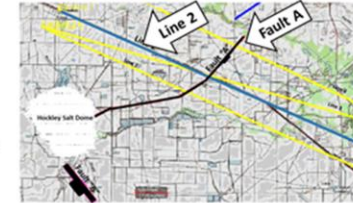
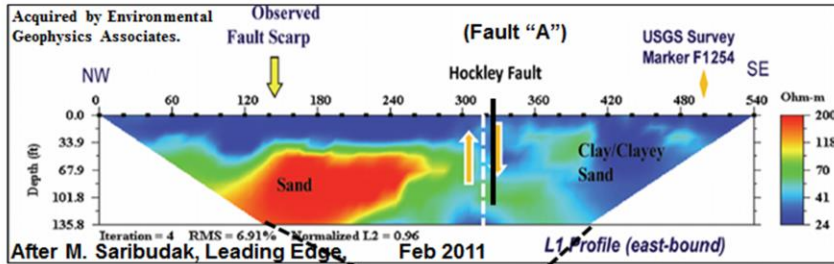

Additional faults suggested.

Are they geologically reasonable, internally consistent, valid?

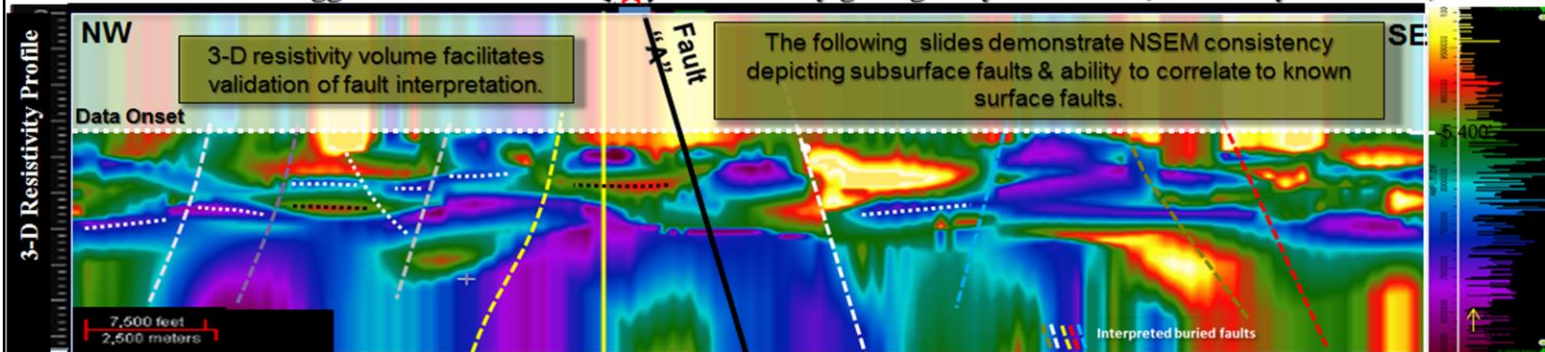

2-D Resistivity Survey ties Lightning-Derived Resistivity Cross-Section



Copyright © 2016
Dynamic Measurement LLC.

Presenter's notes: Dynamic Measurement started because a Commercial Real Estate Developer noticed lightning striking at the same place on his property on the east flank of the Hockley Salt Dome three times with about a 12-month interval between each set of strikes. The west side of upper left shows the Hockley Dome. It also shows a fault which goes to the northeast from the dome, cutting highway 290. There has been damage to roads at the surface along this fault. So a resistivity survey was collected to see if the impact of the fault could be seen in the subsurface. Results were published in The Leading Edge in February of 2011, as shown in the resistivity cross-section at the top. One of Dynamic's Geophysicists, Louie Berent, pulled a lightning-derived apparent-resistivity section out of a lightning analysis project over the Hockley Dome along this same profile. The result is shown in the apparent-resistivity section at the bottom. There is a significant fault, in black, interpreted, which matches the location of the fault interpreted on the 136-foot-deep traditional resistivity section. The depths of the lightning-derived apparent-resistivity section are believed to be from 5,000 feet to about 25,000 feet. Note that this section was generated before Dynamic started muting the data above the first valid data (data onset). Also, note that there are nine other faults interpreted on this cross-section. These faults carry from section to section, and can mapped over a large area, demonstrating how lighting analysis can create a geologic framework for any area with limited subsurface control.

Acknowledgements:



- Les Denham, DML Chief Geophysicist.
- Kathy Haggard, DML Geologist.
- Louie Berent, DML Geophysicist.
- BYU Interns Dustin Northrop and R. Corbin Lewis.
- Tom Ewing (BEG) for regional South Texas geology.
- Bob Hardage (BEG) for Stratton seismic survey.
- Andrea Nelson, my wife, for enduring the startup phase.

Thank You!

- H. Roice Nelson, Jr., Geophysicist
cell: 713.542.2207
e-mail: roice@dynamicmeasurement.com
www.dynamicmeasurement.com
www.dynamicmeasurement.com/TAMU
www.dynamicmeasurement.com/LI
- 211 Baker Road #382
Barker, TX 77413
– Office: 281.579.0172
- 2155 West 700 South #31
Cedar City, UT 84720
– Fax: 435.267.2668

04 October 2016

Copyright © 2016
Dynamic Measurement LLC.